

2023

**Pietred'Arredo**<sup>®</sup>  
naturalmente ricostruite



Handmade  
in Umbria



<i>ARENAL</i>	19	<i>BORGONOVO</i>	211
<i>GRANADA</i>	35	<i>CORTEVECCHIO</i>	219
<i>SANTIAGO</i>	47	<i>CORTONA</i>	223
<i>TEIDE</i>	57	<i>TOSCANO</i>	229
<i>JAVA</i>	67	<i>ETRUSCO</i>	235
<i>CERVINO</i>	75	<i>ALPINO</i>	241
<i>TAOS</i>	79	<i>MONTANO</i>	247
<i>VESUVIO</i>	97	<i>TIROLESE</i>	253
<i>SASSO DI FIUME</i>	103	<i>DOLOMITE</i>	257
<i>RUSTICO</i>	107	<i>VENETO</i>	261
<i>ANTICO MATTONE</i>	115	<i>CANOVA</i>	267
<i>LOKON</i>	123	<i>LIGURE</i>	271
<i>OLKARIA</i>	137	<i>VINTAGE</i>	275
<i>SAKAR</i>	153	<i>TOGA</i>	279
<i>MURIA</i>	169	<i>VICTORY</i>	283
<i>KALOS</i>	173		
<i>CERVINO PANEL</i>	179	<i>PIETRA COMFORT</i>	296
<i>MADERA</i>	183	<i>AIR SYSTEM</i>	297
<i>MILOS</i>	187		
<i>BELMONTE</i>	191		
<i>MISTO UMBRO</i>	199		
<i>MISTO CAMPAGNA</i>	207		



## Creatori di pietra, come la natura.

*Siamo nati all'ombra dei palazzi di Gubbio, la Città di Pietra nel cuore verde d'Italia, l'Umbria, dove lo scalpellino è ancora un mestiere e l'Università dei Muratori è impegnata a tutelare e tramandare l'antica arte muraria. Le nostre radici affondano nella scienza del costruire e la nostra eredità è il sapere artigiano tramandato da generazioni. Da qui siamo partiti e da 40 anni ricerchiamo le pietre più belle per riprodurle in ogni dettaglio.*

### **Stone makers, akin to nature.**

*We were born in the shadow of Gubbio's palaces, the City of Stone in the green heart of Italy, Umbria, where stonecutter is still a trade and the Università dei Muratori undertakes to protect and pass on the ancient masonry. Our roots lie in the science of building and our heritage is the craftsmanship handed down between generations. This is where we began and for 40 years we have been researching the most beautiful stones to reproduce them in every detail.*

### **Steinhersteller, wie die Natur.**

*Wir sind im Schatten der Paläste von Gubbio entstanden, der Stadt aus Stein im grünen Herzen Italiens, in Umbrien, wo das Steinmetzhandwerk noch immer ein Handwerk ist und sich die Universität der Maurer für den Schutz und die Weitergabe der alten Maurerkunst einsetzt. Unsere Wurzeln liegen im wissenschaftlichen Ansatz des Baugewerbes, und unser Erbe ist die über Generationen hinweg weitergegebene Handwerkskunst. Sie war unser Ausgangspunkt und seit 40 Jahren sind wir immer auf der Suche nach den schönsten Steinen, die wir dann bis ins kleinste Detail reproduzieren.*

### **Créateurs de pierre, comme la nature.**

*Nous sommes nés à l'ombre des palais de Gubbio, la Cité de la Pierre qui se dresse en Ombrie, le cœur vert de l'Italie, où le tailleur de pierre est toujours un métier et l'Université des Maçons s'engage à protéger et à transmettre l'art ancien de la maçonnerie. Nous plongeons nos racines dans la science du bâtiment et notre héritage est le savoir-faire transmis depuis des générations. C'est de là que nous sommes partis et nous cherchons les plus belles pierres pour les reproduire dans les moindres détails, depuis 40 ans.*





## Sulle spalle dei giganti: l'eredità della tradizione.

*Il genius loci di Gubbio illumina la visione della nostra impresa, guida il lavoro dei ricercatori, anima le mani sapienti degli artigiani e permea di originale bellezza il nostro prodotto: l'unica pietra naturalmente ricostruita, ideata e interamente realizzata in Italia. Crediamo che la pietra sia il simbolo del legame tra la terra e l'uomo, l'espressione più autentica dell'abitare, la forma ancestrale della dimora che accoglie, protegge, racconta. È questa la filosofia che plasma la nostra pietra ricostruita e imprime su di essa significati che diventano visibili e tangibili sulla sua superficie.*

### **On the shoulders of giants: the legacy of tradition.**

*The genius loci of Gubbio brightens our company's vision, guides the work of researchers, brings the skilled hands of artisans to life and permeates our product with original beauty: the only naturally reconstructed stone, designed and entirely made in Italy. We believe stone symbolises the bond between earth and man, the most authentic expression of living, the ancestral form of the dwelling that welcomes, protects, tells stories. This is the philosophy that shapes our cast stone and marks it with meanings that become visible and tangible on its surface.*

### **Auf den Schultern von Riesen: das Erbe der Tradition.**

*Der Genius Loci von Gubbio ist der Wegweiser für unsere Unternehmensvision, leitet die Arbeit unserer Forscher, belebt die geschickten Hände unserer Handwerker und verleiht unserem Produkt ursprüngliche Schönheit: der einzige Stein, der natürlich rekonstruiert, gestaltet und vollständig in Italien hergestellt wird. Wir glauben, dass der Stein das Symbol für die Verbindung zwischen Erde und Mensch ist, der authentischste Ausdruck der Behausung, die älteste Form eines Unterschlupfs, der uns aufnimmt, schützt und Geschichten erzählt. Dies ist die Philosophie, die unseren rekonstruierten Stein formt und ihm seinen auf der Oberfläche sichtbaren und spürbaren Charakter verleiht.*

### **Sur les épaules des géants: l'héritage de la tradition.**

*Le genius loci de Gubbio éclaire la vision de notre entreprise, guide le travail des chercheurs, anime les mains habiles des artisans et imprègne notre produit d'une beauté originale: la seule pierre naturellement reconstruite, conçue et entièrement fabriquée en Italie. Nous pensons que la pierre est le symbole du lien entre la terre et l'homme, l'expression la plus authentique de l'habitation, la forme ancestrale de la demeure qui accueille, protège, raconte. Telle est la philosophie qui façonne notre pierre reconstituée et lui imprime des significations qui deviennent visibles et tangibles à sa surface.*



## Quarant'anni di ricerca per applicare la cura artigianale su larga scala.

*Pietre d'Arredo è un brand di Colmef Group, eccellenza italiana del settore edile. Una produzione in serie differenziata che imita alla perfezione la molteplicità e l'unicità delle formazioni naturali. Identica alla pietra vera, ma realizzata in laboratorio con metodi artigianali. Siamo l'unica azienda italiana a seguire ogni fase della lavorazione. Tutto avviene nel distretto produttivo di Gubbio: dallo studio al calco, dalla creazione in serie fino alla finitura a mano di ogni elemento.*

### **Forty years of research to apply artisanal care on a large scale.**

*Pietre d'Arredo is a brand of Colmef Group, Italian excellence in the construction sector. A differentiated mass production that perfectly captures the multiplicity and uniqueness of natural formations. Identical to real stone, but developed in a laboratory by means of artisanal methods. We are the only Italian company to carefully follow each processing stage. Everything happens in the Gubbio manufacturing district: from the study to the cast, from mass production to the hand finishing of each element.*

### **40 Jahre Forschung für eine Anwendung des Kunsthandwerks in großem Maßstab.**

*Pietre d'Arredo ist ein Marke der Colmef Group, ein Zeichen italienischer Exzellenz im Baugewerbe. Eine spezielle Serienproduktion, die die Vielfalt und Einzigartigkeit der natürlichen Formationen perfekt nachahmt. Ein Material, das wie echter Stein aussieht, jedoch in der Werkstatt mit handwerklichen Methoden hergestellt wird. Wir sind das einzige Unternehmen in Italien, das jede einzelne Phase der Bearbeitung begleitet. Alle Arbeiten werden im Produktionsbereich in Gubbio ausgeführt: Von der Planung bis zum Guss, von der Massenproduktion bis zur manuellen Endbearbeitung jedes einzelnen Elements.*

### **Quarante ans de recherche pour appliquer l'artisanat à grande échelle.**

*Pietre d'Arredo est une marque de Colmef Group, une excellence italienne dans le secteur du bâtiment. Une production en série différenciée qui imite parfaitement la multiplicité et l'unicité des formations naturelles. Identique à la vraie pierre, mais fabriquée en laboratoire avec des méthodes artisanales. Nous sommes la seule entreprise italienne à suivre chaque étape du traitement. Tout se passe dans l'unité de production de Gubbio: de l'étude à la finition à la main de chaque élément, en passant par le moulage et la création en série.*



## Dalla natura e ritorno: il controllo della filiera.

*Quando in natura troviamo una pietra di particolare bellezza ne preleviamo alcuni campioni e li portiamo nei nostri laboratori. Qui, studiamo accuratamente le caratteristiche che ne determinano l'aspetto e la consistenza, e creiamo un calco per poter riprodurre ogni elemento attraverso una miscela di materiali selezionati. Ogni pietra così ricostruita viene poi colorata con tecniche artigianali che le conferiscono tratti unici, proprio come in natura. Infine, le singole pietre vengono inscatolate pronte per l'installazione, mentre gli originali ritornano al loro luogo di provenienza per essere restituiti alla terra a cui appartengono.*

### **From nature and back: control of the supply chain.**

*Once we discover a particularly beautiful stone in nature, we take a few samples and bring them to our laboratories. Here, we carefully study the characteristics behind its appearance and texture, and create a cast to be able to reproduce each element using different selected materials. Each stone is then coloured via artisan techniques that bestow upon it unique features, just like in nature. Lastly, individual stones are prepared and packed ready for installation, while the originals return to their place of origin to be returned to the land to which they belong.*

### **Aus der Natur und wieder zu ihr zurück: Die Kontrolle der Produktionskette.**

*Wenn wir in der Natur einen Stein von besonderer Schönheit finden, nehmen wir Proben und bringen sie in unsere Labors. Hier untersuchen wir sorgfältig die Merkmale, die sein Aussehen und seine Beschaffenheit bestimmen, und erstellen einen Abguss, um jedes Element mit einer Mischung aus ausgewählten Materialien zu reproduzieren. Jeder Stein wird anschließend mit handwerklichen Techniken gefärbt, die ihm, ganz wie in der Natur, seine Einzigartigkeit verleihen. Schließlich werden die einzelnen rekonstruierten Steine für die Anwendung verpackt, während die Originale an ihren Ursprungsort zurückkehren und dort der Erde zurückgegeben werden.*

### **De la nature et retour à la nature : la maîtrise de la chaîne de fabrication.**

*Lorsque nous trouvons une pierre particulièrement belle dans la nature, nous prélevons quelques échantillons et les apportons à nos laboratoires. Là, nous étudions attentivement les caractéristiques qui déterminent son aspect et sa texture et créons un moulage pour pouvoir reproduire chaque élément à travers un mélange de matériaux sélectionnés. Chaque pierre est ensuite colorée en suivant des techniques artisanales qui lui confèrent des caractéristiques uniques, exactement comme dans la nature. Pour finir, les pierres sont emballées prêtes à être installées, tandis que les originaux retournent à leur lieu d'origine pour être restitués à la terre à laquelle ils appartiennent.*



## Il nostro impegno per un'edilizia che rispetta l'ambiente.

*Con le nostre pietre ricostruite offriamo un'alternativa sostenibile allo sfruttamento della pietra naturale, contribuiamo a preservare le risorse ambientali e promuoviamo un modo più responsabile di abitare questo pianeta così ricco di meraviglie. Abbiamo aderito al Green Building Council Italia, parte del network mondiale World GBC, che sostiene lo sviluppo dell'edilizia sostenibile. La nostra pietra è a bassissima emissione di COV (composti organici volatili) e le sue caratteristiche tecniche rispettano gli standard europei.*

### **Our commitment to a construction industry that respects the environment.**

*Our reconstructed stones provide a sustainable alternative to the exploitation of natural stone, we help preserve environmental resources and promote a more responsible way to inhabit this wonderfully diverse planet. We have joined the Green Building Council Italy, part of the World GBC global network, which supports the development of a sustainable construction industry. Our stone has extremely low emission of VOCs (volatile organic compounds) and its technical specifications comply with European standards.*

### **Unser Engagement für ein umweltgerechtes und umweltbewusstes Bauwesen.**

*Mit unseren rekonstruierten Steinen bieten wir eine nachhaltige Alternative zu Natursteinen, tragen zur Schonung der Umweltressourcen bei und fördern einen verantwortungsvolleren Umgang mit diesem wunderschönen Planeten. Wir sind Mitglied des Green Building Council Italia, eines Teils des weltweiten Netzwerks World GBC, das die Entwicklung eines umweltfreundlichen Bauwesens unterstützt. Unser Stein ist mit sehr geringen VOC-Emissionen (flüchtige organische Verbindungen) verbunden, und seine technischen Eigenschaften erfüllen die europäischen Vorschriften.*

### **Notre engagement pour des bâtiments qui respectent l'environnement.**

*Avec nos pierres reconstituées, nous proposons une alternative durable à l'exploitation de la pierre naturelle, nous contribuons à la préservation des ressources environnementales et nous promovons une manière plus responsable d'habiter cette planète si riche en merveilles. Nous avons adhéré au Green Building Council Italie qui fait partie du réseau mondial World GBC lequel soutient le développement de la construction durable. Notre pierre a une très faible émission de COV (composés organiques volatils) et ses caractéristiques techniques sont conformes aux normes européennes.*





## Qualità, affidabilità, durata: l'unica con 50 anni di garanzia.

*La pietra è l'immagine dell'affidabilità: lo percepiamo ogni giorno guardando i palazzi millenari della nostra città, maestosi custodi del tempo che scorre e si deposita sulle loro pareti senza scalfirle. Consapevoli del valore di questa eredità, ci impegniamo ad offrire un sistema completo per la posa dei nostri prodotti che vi permette di usufruire della garanzia di 50 anni. La nostra è una promessa concreta e sincera su cui si fonda il lungo rapporto di fiducia con i nostri clienti. La garanzia viene riconosciuta solo su materiale posato con i nostri prodotti: ARREDOCOLLA o ARREDOFIX per l'incollaggio e ARREDOSTUCCO per la stuccatura.*

### **Quality, reliability, durability: 50-year warranty.**

*Stone is the image of reliability: we perceive it each day by looking at the thousand-year old buildings of our own city, majestic guardians of the time that flows and settles on their walls without scratching them. Aware of the value of this heritage, we undertake to offer a complete system for the installation of our products that allows you to take advantage of the 50-year warranty. The long term relationship with our customers, based on trust, is also founded on our concrete and sincere pledge. The 50 years warranty applies only to the veneer stones installed with our products: ARREDOCOLLA or ARREDOFIX for installation and ARREDOSTUCCO for grouting.*

### **Qualität, Zuverlässigkeit, Haltbarkeit: 50 Jahre Garantieschutz.**

*Stein ist das Sinnbild für Zuverlässigkeit: Das sehen wir jeden Tag, wenn wir die tausendjährigen Gebäude unserer Stadt betrachten, majestätische Zeugen der vergehenden Zeit, die ihre Spuren auf den Mauern hinterlässt, ohne sie zu beschädigen. Da wir uns dieses wertvollen Vermächtnisses bewusst sind, haben wir uns verpflichtet, nicht nur ein Produkt, sondern ein komplettes System für die Verarbeitung unserer Produkte anzubieten, mit dem Sie durch eine 50-jährige Garantie geschützt sind. Unser Versprechen ist konkret und aufrichtig und die Basis des langwährenden Vertrauensverhältnisses zwischen uns und unseren Kunden. Die Garantie wird, nur auf Materialien die mit unseren Produkten wie ARREDOCOLLA oder ARREDOFIX zum Kleben und ARREDOSTUCCO für Fugenmaterial verlegt wurden geben.*

### **Qualité, fiabilité, longue durée: 50 ans de garantie.**

*La pierre est l'image de la fiabilité: nous le percevons chaque jour en regardant les bâtiments millénaires de notre ville, majestueux gardiens du temps qui passe et se pose sur leurs murs sans les érafler. Conscients de la valeur de ce patrimoine, nous nous engageons à vous proposer un système complet de pose de nos produits vous permettant de bénéficier de 50 ans de garantie. Notre promesse concrète et sincère est à la base de la longue relation de confiance avec nos clients. La garantie de 50 ans est reconnue uniquement sur matériel posé avec nos produits: ARREDOCOLLA ou ARREDOFIX pour l'encollage et ARREDOSTUCCO pour le jointoiment.*



# Pietre di design che trasformano le emozioni in spazi da vivere.

*Le ispirazioni per le nostre collezioni ci giungono dalla natura, dalla storia, dall'esperienza umana: luoghi, tradizioni, suoni, colori, profumi e sensazioni si sedimentano e diventano elementi concreti da osservare e toccare, tasselli per costruire case e spazi da sogno, immaginati, desiderati e ora pronti a riempirsi di vita vissuta. Le nostre pietre sono create per modellare con naturalezza ed eleganza gli interni e gli esterni degli edifici di ogni stile, antico o contemporaneo.*

## ***Design stones that turn emotions into living spaces.***

*We are inspired by nature, history, human experience: places, traditions, sounds, colours, scents and sensations that settle down and become material elements to observe and touch, pieces to build dream houses and spaces which had been imagined, desired and are now ready to be real life. Our stones are created in order to naturally and elegantly model interiors and exteriors of buildings of any style, ancient or contemporary.*

## ***Dekorative Steine, die Emotionen in Lebensräume verwandeln.***

*Wir lassen uns von der Natur, der Geschichte und der menschlichen Erfahrung inspirieren: Orte, Traditionen, Klänge, Farben, Düfte und Empfindungen verfestigen sich und werden zu konkreten Elementen, die wir beobachten und anfassen können, zu Bausteinen, aus denen wir Traumhäuser und -räume bauen, die wir uns vorgestellt und gewünscht haben und die nun bereit sind, mit Leben gefüllt zu werden. Unsere Steine sind so konzipiert, dass sie auf natürliche und elegante Weise das Innere und Äußere von Gebäuden aller Stilrichtungen, ob alt oder modern, gestalten.*

## ***Pierres de design qui transforment les émotions en espaces de vie.***

*Les inspirations nous viennent de la nature, de l'histoire, de l'expérience humaine: les lieux, les traditions, les sons, les couleurs, les parfums et les sensations s'installent et deviennent des éléments concrets à observer et à toucher, des pièces pour construire des maisons et des espaces de rêve, imaginés, désirés et maintenant prêts à se remplir de la vraie vie. Nos pierres sont créées pour modeler avec naturel et élégance les intérieurs et les extérieurs des bâtiments de tous styles, anciens ou contemporains.*



# “Arenal

*Ispirata all'arenaria di campo, questa pietra ricostruita evoca le usanze rurali del centro Italia e la trasforma in elemento di design per architetture in stile rustico o contemporaneo: le sue forme irregolari e le superfici strutturate, impreziosite da spacchi e sfumature cromatiche, ricordano in ogni dettaglio gli elementi naturali.*

*Inspired by the sandstone of the field, this reconstructed stone evokes the rural customs of central Italy and turns them into a design element for architecture in the rustic or contemporary style: its irregular shapes and structured surfaces, embellished with cracks and chromatic shades, remind natural elements in every detail.*

*Inspiziert vom Feldsandstein, erinnert dieser rekonstruierte Stein an die bäuerlichen Bräuche Mittelitaliens und verwandelt ihn in ein Gestaltungselement für rustikale oder zeitgenössische Architektur: seine unregelmäßigen Formen und strukturierten Oberflächen, die mit Rissen und Farbnuancen verziert sind, erinnern in jedem Detail an natürliche Elemente.*

*Inspirée du grès des champs, cette pierre reconstituée évoque les coutumes rurales de l'Italie centrale et la transforme en un élément de design pour l'architecture de style rustique ou contemporain: ses formes irrégulières et ses surfaces structurées, agrémentées de fentes et de nuances chromatiques, rappellent les éléments naturels dans les moindres détails.*

# Arenal



BIANCO TERRA



CREMA



GRIGIO LUCE



GRIGIO ANTICO



GRIGIO TERRA



SABBIA



TERRA



MARRONE CHIARO



GRIGIO CHIARO

## SPECIFICHE DI PRODOTTO - PRODUCT SPECIFICATIONS - ANGABEN ZUM PRODUKT - CARACTÉRISTIQUES DU PRODUIT

	DIMENSIONI DIMENSIONS ABMESSUNGEN DIMENSIONS	ALTEZZA HEIGHT HÖHE HAUTEUR	LUNGHEZZA LENGHT LÄNGE LONGUEUR	PESO A CONFEZIONE WEIGHT PER BOX GEWICHT/PACKUNG POIDS PAR BOÎTE	CONFEZIONE* PACKAGING PACKUNG BOÎTE	SPESSORE THICKNESS DICKE ÉPAISSEUR	POSA INSTALLATION VERLEGUNG POSE
<b>ELEMENTI PIANI</b> <b>FLAT ELEMENTS</b> <b>FLACHE ELEMENTE</b> <b>ÉLÉMENTS PLATS</b>	da 30,00 cm <sup>2</sup> a 1225,00 cm <sup>2</sup>	-	-	≈ 34,00 kg (34,00 kg/m <sup>2</sup> )	1,00 m <sup>2</sup> (30,00 m <sup>2</sup> /pallet)	2,00 - 4,00 cm	fugato grouted mit Fuge avec joint
<b>ELEMENTI ANGOLARI</b> <b>CORNER ELEMENTS</b> <b>ECKELEMENTE</b> <b>ÉLÉMENTS D'ANGLE</b>	-	da 8,00 cm a 34,00 cm	da 10,00 cm a 28,00 cm	≈ 24 kg	2,00 m (60,00 m/pallet)	2,00 - 4,00 cm	

RESA - YIELD - VERBRAUCH - RENDEMENT: ARREDOCOLLA 6-7 kg/m<sup>2</sup> / ARREDOSTUCCO 8-10 kg/m<sup>2</sup>

\*Giunto compreso | Joint included | einschließlich Fuge | joint compris ± 5%













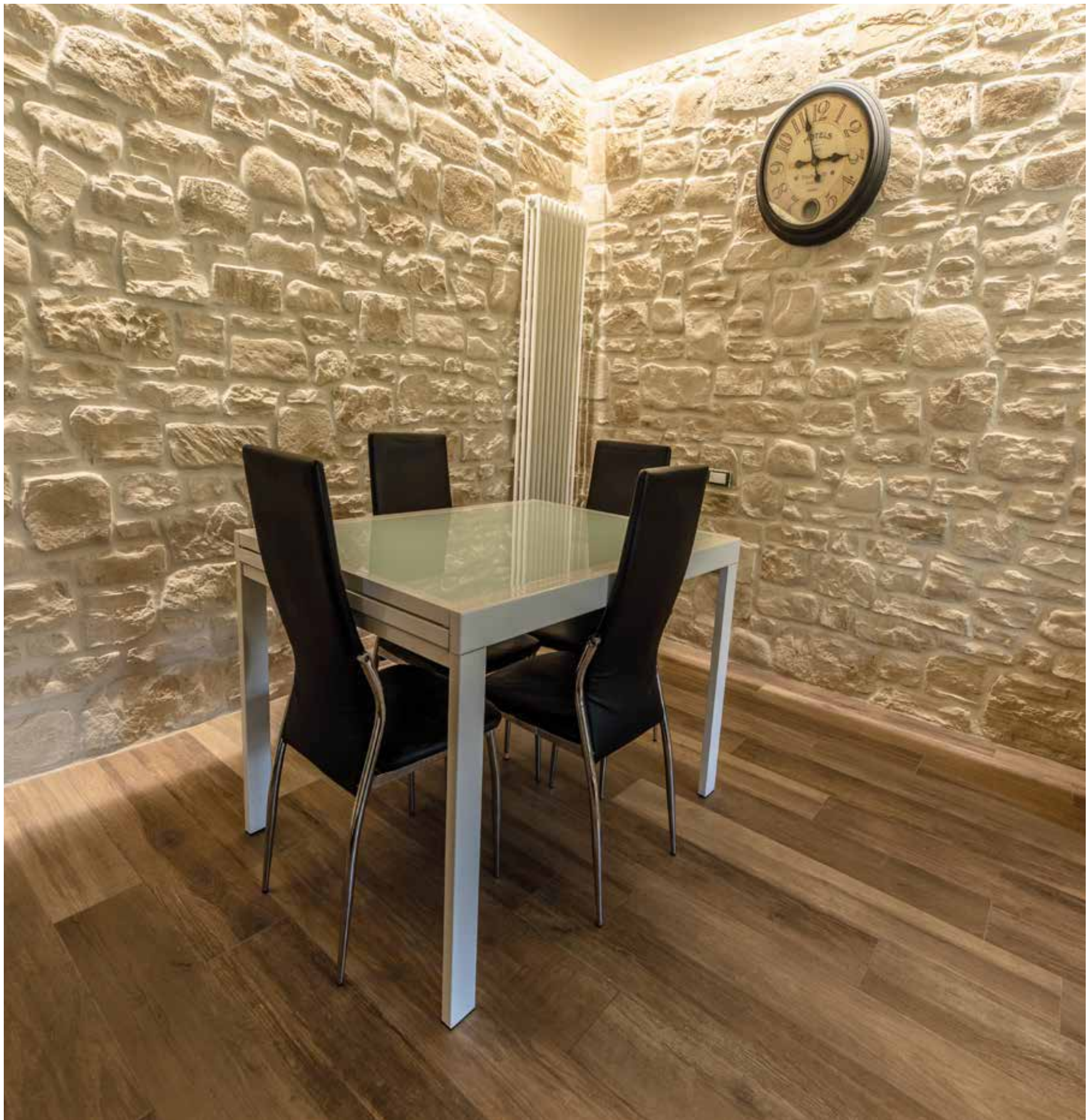







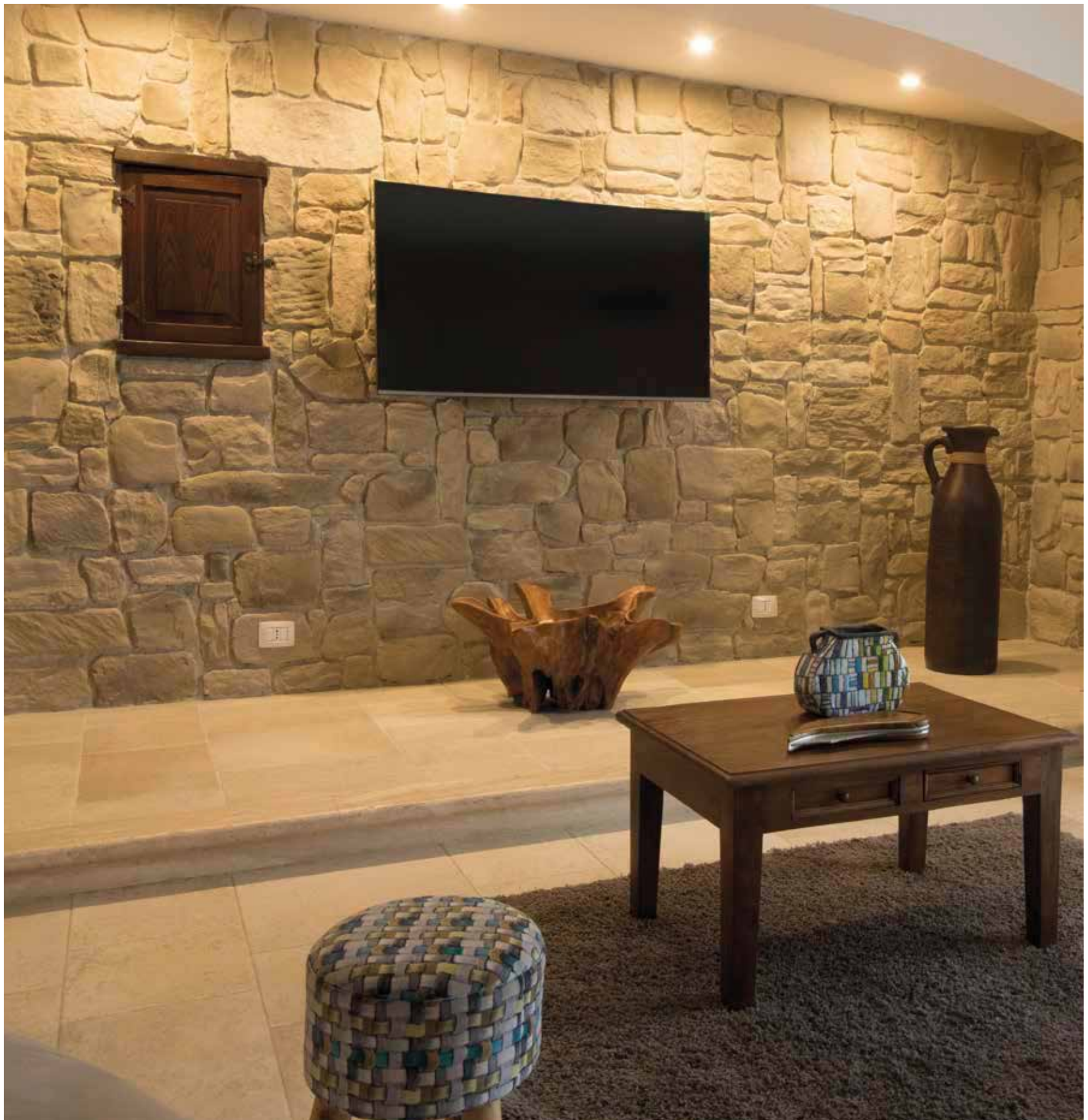





Arenal Grigio Terra



Arenal Grigio Terra





Arenal Sabbia



Arenal Terra



# “Granada

*Superfici a spacco, simili a quelle dell'arenaria, ma modellate in forme squadrate, scolpite dai gesti sicuri degli artigiani: Granada evoca lo stile architettonico delle abitazioni costruite in passato dalle classi più agiate che desideravano conferire alla pietra grezza un aspetto levigato e regolare.*

*Split surfaces, similar to those of sandstone, but modelled in square shapes, sculpted by craftsmen's confident hands: Granada evokes the architectural style of the houses built by the wealthier classes in the past, who wanted to make the rough stone look smooth and regular.*

*Gespaltene Oberflächen, die denen des Sandsteins ähneln, aber zu quadratischen Formen modelliert sind, die von den wissenden Händen der Handwerker geformt wurden: Granada erinnert an den architektonischen Stil der Häuser, die in der Vergangenheit von den wohlhabenderen Schichten gebaut wurden, die dem rauen Stein ein glattes und regelmäßiges Aussehen verleihen wollten.*

*Surfaces clivées, semblables à celles du grès, mais modelées en formes carrées, sculptées par les gestes assurés des artisans : Granada évoque le style architectural des maisons construites dans le passé par les classes les plus aisées qui voulaient donner à la pierre brute un aspect lisse et régulier.*

# Granada



BIANCO TERRA



CREMA



GRIGIO LUCE



GRIGIO ANTICO



GRIGIO TERRA



TERRA



GRIGIO CHIARO



BLU ANTICO

## SPECIFICHE DI PRODOTTO - PRODUCT SPECIFICATIONS - ANGABEN ZUM PRODUKT - CARACTÉRISTIQUES DU PRODUIT

	DIMENSIONI DIMENSIONS ABMESSUNGEN DIMENSIONS	ALTEZZA HEIGHT HÖHE HAUTEUR	LUNGHEZZA LENGHT LÄNGE LONGUEUR	PESO A CONFEZIONE WEIGHT PER BOX GEWICHT/PACKUNG POIDS PAR BOÎTE	CONFEZIONE* PACKAGING PACKUNG BOÎTE	SPESSORE THICKNESS DICKE ÉPAISSEUR	POSA INSTALLATION VERLEGUNG POSE
<b>ELEMENTI PIANI</b> <b>FLAT ELEMENTS</b> <b>FLACHE ELEMENTE</b> <b>ÉLÉMENTS PLATS</b>	da 30,00 cm <sup>2</sup> a 900,00 cm <sup>2</sup>	-	-	≅ 34,00 kg (34,00 kg/m <sup>2</sup> )	1,00 m <sup>2</sup> (30,00 m <sup>2</sup> /pallet)	2,00 - 4,00 cm	fugato grouted mit Fuge avec joint
<b>ELEMENTI ANGOLARI</b> <b>CORNER ELEMENTS</b> <b>ECKELEMENTE</b> <b>ÉLÉMENTS D'ANGLE</b>	-	da 7,00 cm a 15,00 cm	da 8,00 cm a 20,00 cm	≅ 24,00 kg	2,00 m (60,00 m/pallet)	2,00 - 4,00 cm	

RESA - YIELD - VERBRAUCH - RENDEMENT: ARREDOCOLLA 6-7 kg/m<sup>2</sup> / ARREDOSTUCCO 8-10 kg/m<sup>2</sup>

\*Giunto compreso | Joint included | einschließlich Fuge | joint compris ± 5%

















**Granada Grigio Terra** | Scuola di Loiano (MO) | Progetto studiocontini - Foto Davide Galli  
1° Classificato Cat. Edilizia ex novo/non residenziali - PREMIO SOSTENIBILITÀ 2019









# “Santiago

*Questa collezione trae ispirazione dalla pietra calcarea marmosa del Salento, ma si colora di molteplici tinte. La sua superficie è impreziosita da spaccature e tagli particolari che danno corpo e struttura agli elementi squadrati, mentre le sfumature naturali testimoniano lo scorrere del tempo, imitando alla perfezione i mutamenti della pietra autentica.*

*This collection draws inspiration from the marble limestone of Salento, but is coloured with multiple nuances. Its surface is embellished with cracks and particular cuts that give shape and structure to the squared elements, while the natural shades testify to the passage of time and imitate the changes of authentic stone in a perfect way.*

*Diese Kollektion ist vom mergeligen Kalkstein des Salento inspiriert, aber in vielerlei Farbtönen gehalten. Seine Oberfläche ist mit Rissen und speziellen Schliffen verziert, die den quadratischen Elementen Körper und Struktur verleihen, während die natürlichen Schattierungen vom Lauf der Zeit zeugen und die unterschiedlichen Ausprägungen des echten Steins perfekt imitieren.*

*Cette collection s'inspire du marbre calcaire du Salento, mais se colore de teintes multiples. Sa surface est ornée de craquelures et de coupes particulières qui donnent du corps et de la structure aux éléments carrés, tandis que les nuances naturelles témoignent du passage du temps, imitant parfaitement les changements de la pierre authentique.*

# Santiago



GRIGIO ANTICO



BIANCO



GRIGIO TERRA



TERRA



MARRONE SCURO



ROSATO



GRIGIO CHIARO



BLU ANTICO

## SPECIFICHE DI PRODOTTO - PRODUCT SPECIFICATIONS - ANGABEN ZUM PRODUKT - CARACTÉRISTIQUES DU PRODUIT

	DIMENSIONI DIMENSIONS ABMESSUNGEN DIMENSIONS	ALTEZZA HEIGHT HÖHE HAUTEUR	LUNGHEZZA LENGHT LÄNGE LONGUEUR	PESO A CONFEZIONE WEIGHT PER BOX GEWICHT/PACKUNG POIDS PAR BOÎTE	CONFEZIONE* PACKAGING PACKUNG BOÎTE	SPESSORE THICKNESS DICKE ÉPAISSEUR	POSA INSTALLATION VERLEGUNG POSE
<b>ELEMENTI PIANI</b> <b>FLAT ELEMENTS</b> <b>FLACHE ELEMENTE</b> <b>ÉLÉMENTS PLATS</b>	da 50,00 cm <sup>2</sup> a 1200,00 cm <sup>2</sup>	-	-	≅ 35,00 kg (43,00 kg/m <sup>2</sup> )	0,80 m <sup>2</sup> (24,00 m <sup>2</sup> /pallet)	4,00 - 5,00 cm	fugato grouted mit Fuge avec joint
<b>ELEMENTI ANGOLARI</b> <b>CORNER ELEMENTS</b> <b>ECKELEMENTE</b> <b>ÉLÉMENTS D'ANGLE</b>	-	da 8,00 cm a 35,00 cm	da 12,00 cm a 22,00 cm	≅ 23,00 kg	1,50 m (45,00 m/pallet)	4,00 - 5,00 cm	

RESA - YIELD - VERBRAUCH - RENDEMENT: ARREDOCOLLA 6-7 kg/m<sup>2</sup> / ARREDOSTUCCO 8-10 kg/m<sup>2</sup>

\*Giunto compreso | Joint included | einschließlich Fuge | joint compris ± 5%







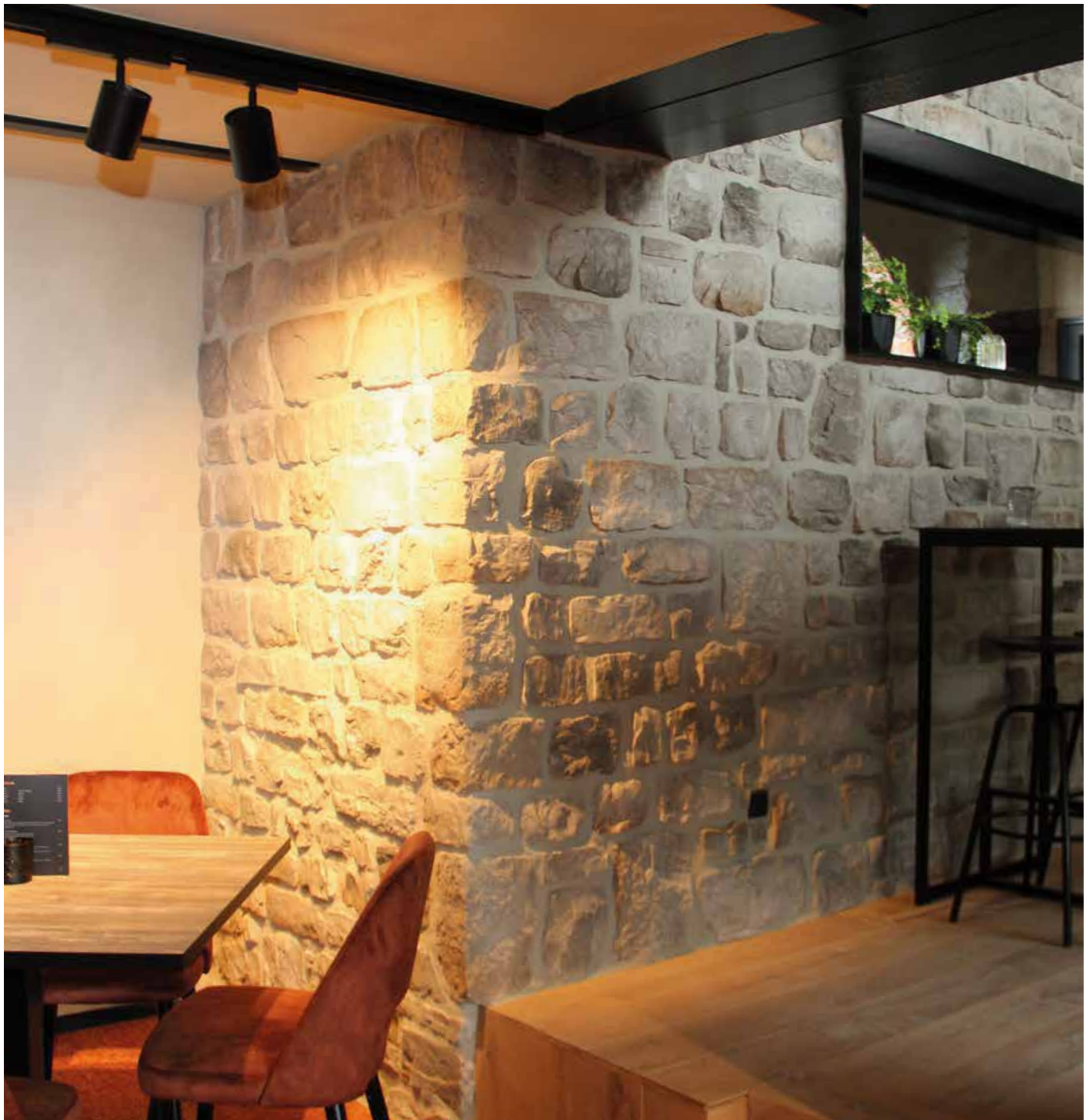











# “Teide

*Elementi arrotondati dalle forme irregolari ispirati al marmo di Botticino e all'edilizia tipica dei borghi stagliati sulle rive del Lago di Garda, dove l'atmosfera nordica e quella mediterranea sembrano incontrarsi per plasmare un paesaggio fiabesco. La superficie increspata e luminosa di questa pietra evoca l'immagine delle acque baciato dal sole, conferendo alle pareti un aspetto raffinatissimo, ma naturale.*

*Rounded elements with irregular shapes inspired by Botticino marble and by the typical buildings of the villages standing on the shores of Lake Garda, where the Nordic and Mediterranean atmospheres seem to match and shape a fairytale landscape. The rippled and luminous surface of this stone evokes the image of sun-kissed waters, thus giving the walls an extremely refined, yet natural look.*

*Abgerundete Elemente mit unregelmäßigen Formen, die vom Botticino-Marmor und den typischen Gebäuden der Dörfer am Gardasee inspiriert sind, wo sich nordische und mediterrane Atmosphären zu einer märchenhaften Landschaft zu vereinen scheinen. Die gewellte, leuchtende Oberfläche dieses Steins erinnert an sonnenverwöhnte Gewässer und verleiht den Wänden ein sehr feines und zugleich natürliches Aussehen.*

*Éléments arrondis aux formes irrégulières inspirés du marbre de Botticino et de la construction typique des villages se découpant sur les rives du Lac de Garde, où l'atmosphère nordique et méditerranéenne semblent se rencontrer pour façonner un paysage de conte de fées. La surface ondulée et lumineuse de cette pierre évoque l'image des eaux ensoleillées, donnant aux murs un aspect très raffiné, mais naturel.*

# Teide



BIANCO TERRA



BIANCO



GRIGIO TERRA



TERRA



GRIGIO CHIARO

## SPECIFICHE DI PRODOTTO - PRODUCT SPECIFICATIONS - ANGABEN ZUM PRODUKT - CARACTÉRISTIQUES DU PRODUIT

	DIMENSIONI DIMENSIONS ABMESSUNGEN DIMENSIONS	ALTEZZA HEIGHT HÖHE HAUTEUR	LUNGHEZZA LENGHT LÄNGE LONGUEUR	PESO A CONFEZIONE WEIGHT PER BOX GEWICHT/PACKUNG POIDS PAR BOÎTE	CONFEZIONE* PACKAGING PACKUNG BOÎTE	SPESSORE THICKNESS DICKE ÉPAISSEUR	POSA INSTALLATION VERLEGUNG POSE
<b>ELEMENTI PIANI</b> <b>FLAT ELEMENTS</b> <b>FLACHE ELEMENTE</b> <b>ÉLÉMENTS PLATS</b>	da 20,00 cm <sup>2</sup> a 1200,00 cm <sup>2</sup>	-	-	≅ 32,00 kg (43,00 kg/m <sup>2</sup> )	0,80 m <sup>2</sup> (24,00 m <sup>2</sup> /pallet)	2,50 - 5,00 cm	fugato grouted mit Fuge avec joint
<b>ELEMENTI ANGOLARI</b> <b>CORNER ELEMENTS</b> <b>ECKELEMENTE</b> <b>ÉLÉMENTS D'ANGLE</b>	-	da 15,00 cm a 36,00 cm	da 8,00 cm a 25,00 cm	≅ 16,00 kg	1,00 m (30,00 m/pallet)	2,50 - 5,00 cm	

RESA - YIELD - VERBRAUCH - RENDEMENT: ARREDOCOLLA 6-7 kg/m<sup>2</sup> / ARREDOSTUCCO 10-12 kg/m<sup>2</sup>

\*Giunto compreso | Joint included | einschließlich Fuge | joint compris ± 5%





















# “Java

*Questa collezione dalle forme irregolari, porta con sé la ruvidezza della pietra e la solennità del marmo, il candore delle formazioni calcaree e la concretezza terrigna dell'arenaria: una commistione di immagini e sensazioni che può permeare ambienti rustici o moderni, ottenendo contrasti inediti, ma sempre armonici ed equilibrati.*

*This collection with irregular shapes contains the roughness of stone and the solemnity of marble, the whiteness of limestone formations and the earthy concreteness of the sandstone: a mixture of images and sensations that may permeate rustic or modern environments, thus obtaining unprecedented contrasts that are always harmonious and balanced.*

*Diese Kollektion mit ihren unregelmäßigen Formen bringt die Rauheit des Steins und die Feierlichkeit des Marmors, das Weiß der Kalksteinformationen und die erdige Konkretheit des Sandsteins mit sich: eine Mischung aus Bildern und Empfindungen, die rustikale oder moderne Umgebungen durchdringen können und zu ungewöhnlichen, aber immer harmonischen und ausgewogenen Kontrasten führen.*

*Cette collection aux formes irrégulières apporte la rugosité de la pierre et la solennité du marbre, la blancheur des formations calcaires et le concret terreux du grès: un mélange d'images et de sensations qui peuvent imprégner les environnements rustiques ou modernes, obtenant des contrastes inédits, mais toujours harmonieux et équilibrés.*

# Java



BIANCO



GRIGIO TERRA



TERRA



GRIGIO CHIARO

## SPECIFICHE DI PRODOTTO - PRODUCT SPECIFICATIONS - ANGABEN ZUM PRODUKT - CARACTÉRISTIQUES DU PRODUIT

	DIMENSIONI DIMENSIONS ABMESSUNGEN DIMENSIONS	ALTEZZA HEIGHT HÖHE HAUTEUR	LUNGHEZZA LENGHT LÄNGE LONGUEUR	PESO A CONFEZIONE WEIGHT PER BOX GEWICHT/PACKUNG POIDS PAR BOÎTE	CONFEZIONE* PACKAGING PACKUNG BOÎTE	SPESSORE THICKNESS DICKE ÉPAISSEUR	POSA INSTALLATION VERLEGUNG POSE
<b>ELEMENTI PIANI</b> <b>FLAT ELEMENTS</b> <b>FLACHE ELEMENTE</b> <b>ÉLÉMENTS PLATS</b>	da 20,00 cm <sup>2</sup> a 1220,00 cm <sup>2</sup>	-	-	≈ 34,00 kg (43,00 kg/m <sup>2</sup> )	0,80 m <sup>2</sup> (24,00 m <sup>2</sup> /pallet)	2,50 - 5,00 cm	fugato grouted mit Fuge avec joint
<b>ELEMENTI ANGOLARI</b> <b>CORNER ELEMENTS</b> <b>ECKELEMENTE</b> <b>ÉLÉMENTS D'ANGLE</b>	-	da 8,00 cm a 36,00 cm	da 8,00 cm a 25,00 cm	≈ 18,00 kg	1,00 m (30,00 m/pallet)	2,50 - 5,00 cm	

RESA - YIELD - VERBRAUCH - RENDEMENT: ARREDOCOLLA 6-7 kg/m<sup>2</sup> / ARREDOSTUCCO 10-12 kg/m<sup>2</sup>

\*Giunto compreso | Joint included | einschließlich Fuge | joint compris ± 5%

















# “Cervino

*Caratterizzata da superfici frastagliate e forme appuntite e spigolose come la vetta da cui prende il nome, il Cervino, maestoso cimiero tra l'Italia e la Svizzera, questa pietra si ispira all'edilizia alpina, carica di una poetica austera che testimonia il rapporto complesso tra l'uomo e l'alta montagna.*

*Characterised by jagged surfaces and pointed and angular shapes, such as the summit from which it takes its name, the Mount Cervino, a majestic crest between Italy and Switzerland, this stone is inspired by Alpine construction, expression of austere poetics testifying to the complex relationship between man and high mountains.*

*Charakteristisch sind die zerklüfteten Oberflächen und die scharfen, kantigen Formen, wie der Gipfel, von dem er seinen Namen hat, das Matterhorn, ein majestätischer Bergrücken zwischen Italien und der Schweiz. Dieser Stein ist von der alpinen Bauweise inspiriert, aufgeladen mit einer strengen Poesie, die von der komplexen Beziehung zwischen dem Menschen und den hohen Bergen zeugt.*

*Caractérisée par des surfaces découpées et des formes pointues et anguleuses comme le sommet dont elle tire son nom, Cervino, crête majestueuse entre l'Italie et la Suisse, cette pierre s'inspire de la construction alpine, chargée d'une poésie austère qui témoigne de la relation complexe entre l'homme et la haute montagne.*

# Cervino



GRIGIO ANTICO



GRIGIO CHIARO

## SPECIFICHE DI PRODOTTO - PRODUCT SPECIFICATIONS - ANGABEN ZUM PRODUKT - CARACTÉRISTIQUES DU PRODUIT

	DIMENSIONI DIMENSIONS ABMESSUNGEN DIMENSIONS	ALTEZZA HEIGHT HÖHE HAUTEUR	LUNGHEZZA LENGTH LÄNGE LONGUEUR	PESO A CONFEZIONE WEIGHT PER BOX GEWICHT/PACKUNG POIDS PAR BOÎTE	CONFEZIONE* PACKAGING PACKUNG BOÎTE	SPESSORE THICKNESS DICKE ÉPAISSEUR	POSA INSTALLATION VERLEGUNG POSE
<b>ELEMENTI PIANI FLAT ELEMENTS FLACHE ELEMENTE ÉLÉMENTS PLATS</b>	da 20,00 cm <sup>2</sup> a 1220,00 cm <sup>2</sup>	-	-	≈ 40,00 kg (40,00 kg/m <sup>2</sup> )	1,00 m <sup>2</sup> (25,00 m <sup>2</sup> /pallet)	2,50 - 5,00 cm	fugato/ a secco  grouted/ dry stacked
<b>ELEMENTI ANGOLARI CORNER ELEMENTS ECKELEMENTE ÉLÉMENTS D'ANGLE</b>	-	da 8,00 cm a 36,00 cm	da 8,00 cm a 25,00 cm	≈ 28,00 kg	2,00 m (50,00 m/pallet)	2,50 - 5,00 cm	mit Fuge/ trocken avec joint/ joint sec

**RESA - YIELD - VERBRAUCH - RENDEMENT: ARREDOCOLLA 6-7 kg/m<sup>2</sup> / ARREDOSTUCCO 10-12 kg/m<sup>2</sup>**

Per posa a secco prevedere nell'ordine un quantitativo di pietra maggiora di ≈ 15% | For dry stacked installation, the quantity of stone ordered should be increased by ≈ 15%

Für die Trockenverlegung muss in der Bestellung eine Menge von ≈ 15% zusätzlich vorgesehen werden | Pour pose à sec, prévoir dans la commande une quantité de pierre majorée de ≈ 15%

\*Giunto compreso | Joint included | einschließlich Fuge | joint compris ± 5%







# “Taos

*Ispirata alla pietra calcarea del Conero, Taos porta con sé gli echi di storie millenarie come quelle che risuonano nei centri storici medievali di molte zone d'Italia. Semplice eppure maestosa, questa pietra ricostruita testimonia con solennità lo scorrere del tempo e sembra farsi custode silenziosa delle memorie di coloro che la abitano.*

*Inspired by the Conero limestone, Taos has echoes of millenary stories inside, such as those resonating in the medieval historic centres of many areas of Italy. Simple yet majestic, this reconstructed stone solemnly testifies to the passage of time and seems to become a silent guardian of all the memories of those living there.*

*Inspiziert vom Kalkstein des Conero trägt Taos das Echo jahrtausendealter Geschichten in sich, wie sie in den mittelalterlichen Stadtzentren vieler Teile Italiens nachklingen. Dieser schlichte und doch majestätische rekonstruierte Stein legt feierlich Zeugnis ab vom Lauf der Zeit und scheint zum stillen Wächter der Erinnerungen derer zu werden, die ihn bewohnen.*

*Inspirée du calcaire du Conero, Taos apporte avec elle les échos d'histoires millénaires telles que celles qui résonnent dans les centres historiques médiévaux de nombreuses régions d'Italie. Simple mais majestueuse, cette pierre reconstituée témoigne solennellement du passage du temps et semble devenir la gardienne silencieuse des souvenirs de ceux qui l'habitent.*

# Taos



BIANCO



BIANCO ANTICO



MARRONE ANTICO



GRIGIO TERRA



MARRONE CHIARO

## SPECIFICHE DI PRODOTTO - PRODUCT SPECIFICATIONS - ANGABEN ZUM PRODUKT - CARACTÉRISTIQUES DU PRODUIT

	DIMENSIONI DIMENSIONS ABMESSUNGEN DIMENSIONS	ALTEZZA HEIGHT HÖHE HAUTEUR	LUNGHEZZA LENGHT LÄNGE LONGUEUR	PESO A CONFEZIONE WEIGHT PER BOX GEWICHT/PACKUNG POIDS PAR BOÎTE	CONFEZIONE* PACKAGING PACKUNG BOÎTE	SPESSORE THICKNESS DICKE ÉPAISSEUR	POSA INSTALLATION VERLEGUNG POSE
<b>ELEMENTI PIANI</b> <b>FLAT ELEMENTS</b> <b>FLACHE ELEMENTE</b> <b>ÉLÉMENTS PLATS</b>	da 90,00 cm <sup>2</sup> a 500,00 cm <sup>2</sup>	-	-	≅ 35,00 kg (35,00 kg/m <sup>2</sup> )	1,00 m <sup>2</sup> (30,00 m <sup>2</sup> /pallet)	3,00 - 5,00 cm	fugato grouted mit Fuge avec joint
<b>ELEMENTI ANGOLARI</b> <b>CORNER ELEMENTS</b> <b>ECKELEMENTE</b> <b>ÉLÉMENTS D'ANGLE</b>	-	da 10,00 cm a 20,00 cm	da 10,00 cm a 25,00 cm	≅ 33,00 kg	2,00 m (60,00 m/pallet)	3,00 - 5,00 cm	

RESA - YIELD - VERBRAUCH - RENDEMENT: ARREDOCOLLA 6-7 kg/m<sup>2</sup> / ARREDOSTUCCO 8-10 kg/m<sup>2</sup>

\*Giunto compreso | Joint included | einschließlich Fuge | joint compris ± 5%







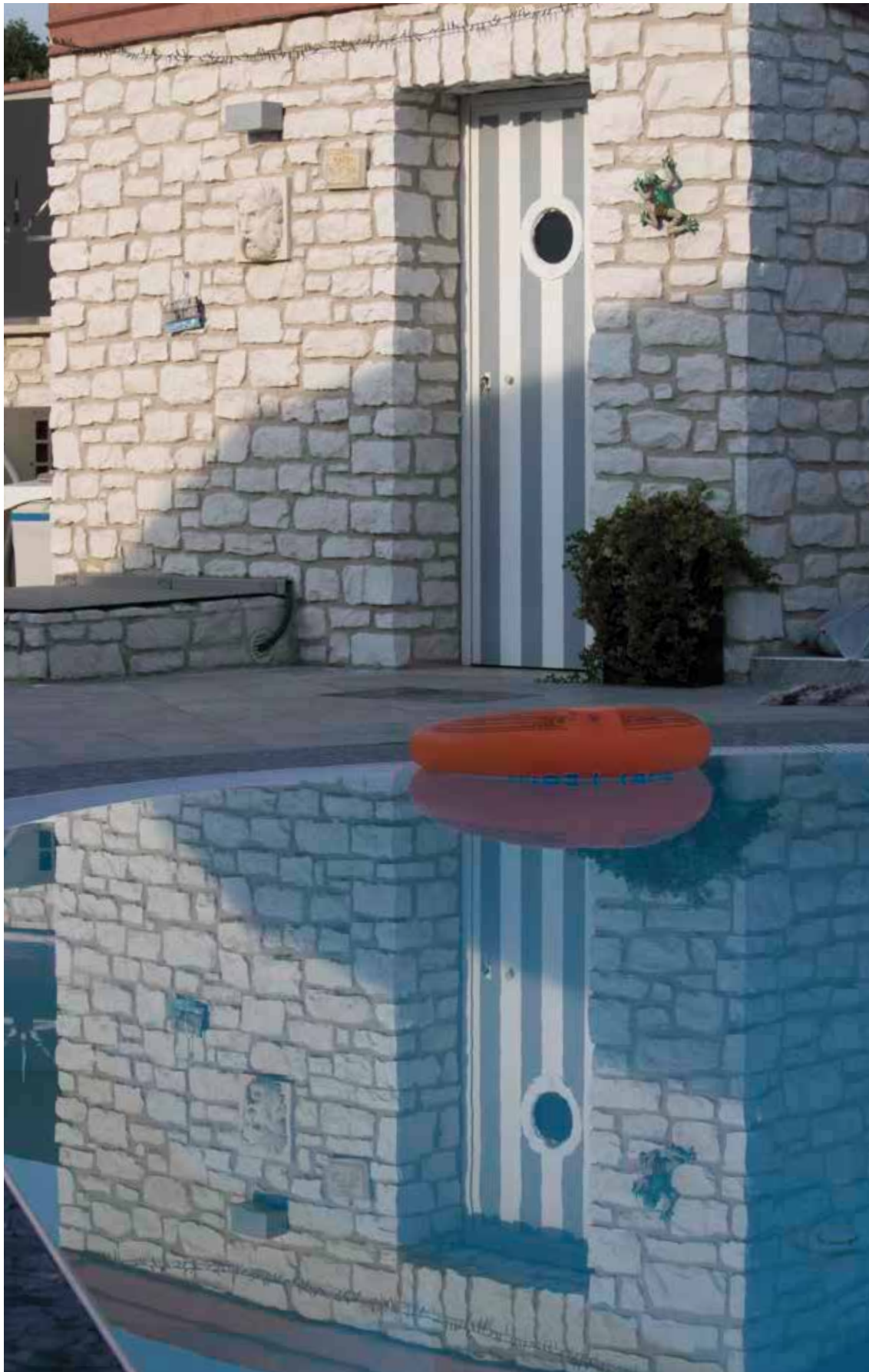





























# “Vesuvio

*Dall'aspetto leggero e poroso, ma allo stesso tempo solido come la terra stessa, Vesuvio è simile alla pietra di tufo che ha origine dall'accumulo di materie vulcaniche e frammenti di calcare e silice. Si ispira ai palazzi dell'antica Parthènope, il cuore arcaico di Napoli, la città sorta sopra la cava da cui proveniva la pietra utilizzata per costruirla.*

*Having a light and porous appearance, still solid like the earth itself, Vesuvio is similar to tuff stone which originates from the accumulation of volcanic materials and fragments of limestone and silica. It is inspired by the palaces of ancient Parthènope, the archaic heart of Naples, the city built over the quarry from which the stone used to build it originated.*

*Vesuvio hat ein leichtes und poröses Aussehen, ist aber gleichzeitig so fest wie die Erde selbst. Er ähnelt dem Tuffstein, der durch die Anhäufung von vulkanischem Material und Bruchstücken von Kalkstein und Kieselsäure entsteht. Es ist inspiriert von den Gebäuden des antiken Parthènope, dem archaischen Herzen Neapels, der Stadt, die über dem Steinbruch entstand, aus dem der Stein für ihre Gebäude stammte.*

*D'apparence légère et poreuse, mais en même temps solide comme la terre elle-même, Vesuvio est semblable à la pierre de tuf qui provient de l'accumulation de matériaux volcaniques et de fragments de calcaire et de silice. Elle s'inspire des palais de l'antique Parthénope, le cœur archaïque de Naples, la ville bâtie sur la carrière d'où provenait la pierre utilisée pour sa construction.*

# Vesuvio



CREMA



SABBIA

## SPECIFICHE DI PRODOTTO - PRODUCT SPECIFICATIONS - ANGABEN ZUM PRODUKT - CARACTÉRISTIQUES DU PRODUIT

	DIMENSIONI DIMENSIONS ABMESSUNGEN DIMENSIONS	ALTEZZA HEIGHT HÖHE HAUTEUR	LUNGHEZZA LENGHT LÄNGE LONGUEUR	PESO A CONFEZIONE WEIGHT PER BOX GEWICHT/PACKUNG POIDS PAR BOÎTE	CONFEZIONE* PACKAGING PACKUNG BOÎTE	SPESSORE THICKNESS DICKE ÉPAISSEUR	POSA INSTALLATION VERLEGUNG POSE
<b>ELEMENTI PIANI</b> <b>FLAT ELEMENTS</b> <b>FLACHE ELEMENTE</b> <b>ÉLÉMENTS PLATS</b>	da 60,00 cm <sup>2</sup> a 1200,00 cm <sup>2</sup>	-	-	≈ 36,00 kg (23,00 kg/m <sup>2</sup> )	1,60 m <sup>2</sup> (40,00 m <sup>2</sup> /pallet)	≈ 2,00 cm	fugato grouted mit Fuge avec joint
<b>ELEMENTI ANGOLARI</b> <b>CORNER ELEMENTS</b> <b>ECKELEMENTE</b> <b>ÉLÉMENTS D'ANGLE</b>	-	da 8,00 cm a 27,00 cm	da 8,00 cm a 25,00 cm	≈ 20,00 kg	2,00 m (60,00 m/pallet)	≈ 2,00 cm	

RESA - YIELD - VERBRAUCH - RENDEMENT: ARREDOCOLLA 6-7 kg/m<sup>2</sup> / ARREDOSTUCCO 6-8 kg/m<sup>2</sup>

\*Giunto compreso | Joint included | einschließlich Fuge | joint compris ± 5%











# “Sasso di Fiume

*Rotonda e levigata, Sasso di Fiume si ispira alle murature di alcuni centri rurali ed evoca la quiete che avvolge le rive dei ruscelli nelle giornate estive, immerse in una realtà fluida che scorre in armonia con il tempo e lo spazio. Questa pietra richiama alla mente immagini di paesaggi fluviali e lacustri: un omaggio al dinamismo della natura e alla capacità modellatrice dell'acqua che plasma il mondo con il semplice atto di attraversarlo.*

*Round and smooth, Sasso di Fiume is inspired by the walls of some rural centres and evokes the quietness surrounding the banks of streams on summer days, which are immersed in a fluid reality that flows in harmony with time and space. This stone evokes images of river and lake landscapes: a tribute to the dynamism of nature and to water's shaping ability that moulds the whole world by simply crossing it.*

*Der runde und glatte Sasso di Fiume ist von den Mauern einiger ländlicher Gegenden inspiriert und erinnert an die Ruhe, die an Sommertagen an den Ufern von Bächen herrscht, eingetaucht in fließende Gewässer, die in Harmonie mit Zeit und Raum dahingleiten. Dieser Stein erinnert an Fluss- und Seenlandschaften: eine Hommage an die Dynamik der Natur und die Gestaltungskraft des Wassers, das die Welt durch den einfachen Akt des Durchfließens formt.*

*Ronde et lisse, Sasso di Fiume s'inspire des maçonneries de certains centres ruraux et évoque le calme qui entoure les rives des ruisseaux les jours d'été, immergées dans une réalité fluide qui coule en harmonie avec le temps et l'espace. Cette pierre évoque des images de paysages fluviaux et lacustres: un hommage au dynamisme de la nature et à la capacité de modelage de l'eau qui façonne le monde par le simple fait de le traverser.*

# Sasso di Fiume



CREMA



GRIGIO TERRA



GRIGIO MIX



CENERE

## SPECIFICHE DI PRODOTTO - PRODUCT SPECIFICATIONS - ANGABEN ZUM PRODUKT - CARACTÉRISTIQUES DU PRODUIT

	DIMENSIONI DIMENSIONS ABMESSUNGEN DIMENSIONS	ALTEZZA HEIGHT HÖHE HAUTEUR	LUNGHEZZA LENGHT LÄNGE LONGUEUR	PESO A CONFEZIONE WEIGHT PER BOX GEWICHT/PACKUNG POIDS PAR BOÎTE	CONFEZIONE* PACKAGING PACKUNG BOÎTE	SPESSORE THICKNESS DICKE ÉPAISSEUR	POSA INSTALLATION VERLEGUNG POSE
<b>ELEMENTI PIANI</b> <b>FLAT ELEMENTS</b> <b>FLACHE ELEMENTE</b> <b>ÉLÉMENTS PLATS</b>	da 40,00 cm <sup>2</sup> a 500,00 cm <sup>2</sup>	-	-	≈ 34,00 kg (30,00 kg/m <sup>2</sup> )	1,00 m <sup>2</sup> (30,00 m <sup>2</sup> /pallet)	3,00 - 5,00 cm	fugato grouted mit Fuge avec joint
<b>ELEMENTI ANGOLARI</b> <b>CORNER ELEMENTS</b> <b>ECKELEMENTE</b> <b>ÉLÉMENTS D'ANGLE</b>	-	da 9,00 cm a 21,00 cm	da 3,00 cm a 14,00 cm	≈ 15,00 kg	2,00 m (60,00 m/pallet)	3,00 - 5,00 cm	

RESA - YIELD - VERBRAUCH - RENDEMENT: ARREDOCOLLA 6-7 kg/m<sup>2</sup> / ARREDOSTUCCO 10-12 kg/m<sup>2</sup>

\*Giunto compreso | Joint included | einschließlich Fuge | joint compris ± 5%







# “ Rustico

*Ispirata alle forme, alla ruvidezza e alla consistenza del mattone in terracotta usato come elemento decorativo in epoca rinascimentale, questa tipologia di mattone evoca atmosfere familiari, semplici, ma raffinate, che fanno da sfondo a storie solide e tangibili, ben radicate nei sentimenti di chi le abita.*

*Inspired by the shapes, roughness and consistency of the terracotta brick used as a decorative element in the Renaissance period, this collection evokes familiar, simple yet refined atmospheres, which give a background to solid and tangible stories that are well rooted in the feelings of those living there.*

*Inspiziert von den Formen, der Rauheit und der Textur der Terrakotta-Ziegel, die in der Renaissance als dekorative Elemente verwendet wurden, diese Kollektion imitiert all diese Schattierungen in Perfektion und fügt Weiß hinzu, um den Charme des antiken Ziegels in moderne Gebäude mit zeitgenössischem Design zu übertragen.*

*Inspirée des formes, de la rugosité et de la consistance de la brique en terre cuite utilisée comme élément décoratif à l'époque de la Renaissance, ce type de briques évoque des atmosphères familières, simples mais raffinées, qui sont la toile de fond d'histoires solides et tangibles, bien ancrées dans les sentiments de ceux qui y vivent.*

# Rustico



BIANCO\*\*



ASTER



IBERIS



SILENE



ANEMONE

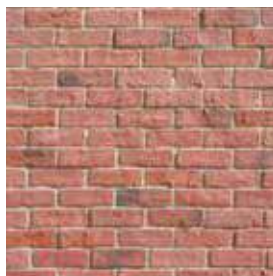

FLOX

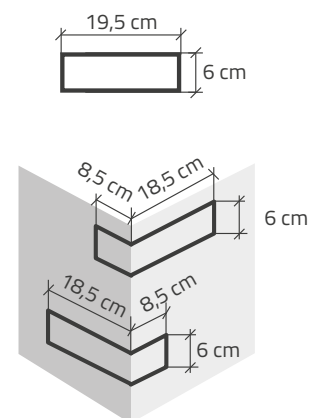

## SPECIFICHE DI PRODOTTO - PRODUCT SPECIFICATIONS - ANGABEN ZUM PRODUKT - CARACTÉRISTIQUES DU PRODUIT

	DIMENSIONI DIMENSIONS ABMESSUNGEN DIMENSIONS	ALTEZZA HEIGHT HÖHE HAUTEUR	LUNGHEZZA LENGHT LÄNGE LONGUEUR	PESO A CONFEZIONE WEIGHT PER BOX GEWICHT/PACKUNG POIDS PAR BOÎTE	CONFEZIONE* PACKAGING PACKUNG BOÎTE	SPESSORE THICKNESS DICKE ÉPAISSEUR	POSA INSTALLATION VERLEGUNG POSE
<b>ELEMENTI PIANI</b> <b>FLAT ELEMENTS</b> <b>FLACHE ELEMENTE</b> <b>ÉLÉMENTS PLATS</b>	≈ 117,00 cm <sup>2</sup>	≈ 6,00 cm	≈ 19,50 cm	≈ 16,00 kg (16,00 kg/m <sup>2</sup> )	1,00 m <sup>2</sup> (50,00 m <sup>2</sup> /pallet)	1,00 - 1,50 cm	fugato grouted mit Fuge avec joint
				<b>BIANCO</b> ≈ 24,00 kg (16,00 kg/m <sup>2</sup> )	<b>BIANCO</b> 1,50 m <sup>2</sup> (45,00 m <sup>2</sup> /pallet)		
<b>ELEMENTI ANGOLARI</b> <b>CORNER ELEMENTS</b> <b>ECKELEMENTE</b> <b>ÉLÉMENTS D'ANGLE</b>	-	≈ 6,00 cm	8,50 - 18,50 cm	≈ 12,50 kg	2,00 m (100,00 m <sup>2</sup> /pallet)	2,00 cm	

RESA - YIELD - VERBRAUCH - RENDEMENT: ARREDOCOLLA 6-7 kg/m<sup>2</sup> / ARREDOSTUCCO 6-8 kg/m<sup>2</sup>

\*Giunto compreso | Joint included | einschließlich Fuge | joint compris ± 5%

\*\* per interni | for interiors | für Innen | pour interne







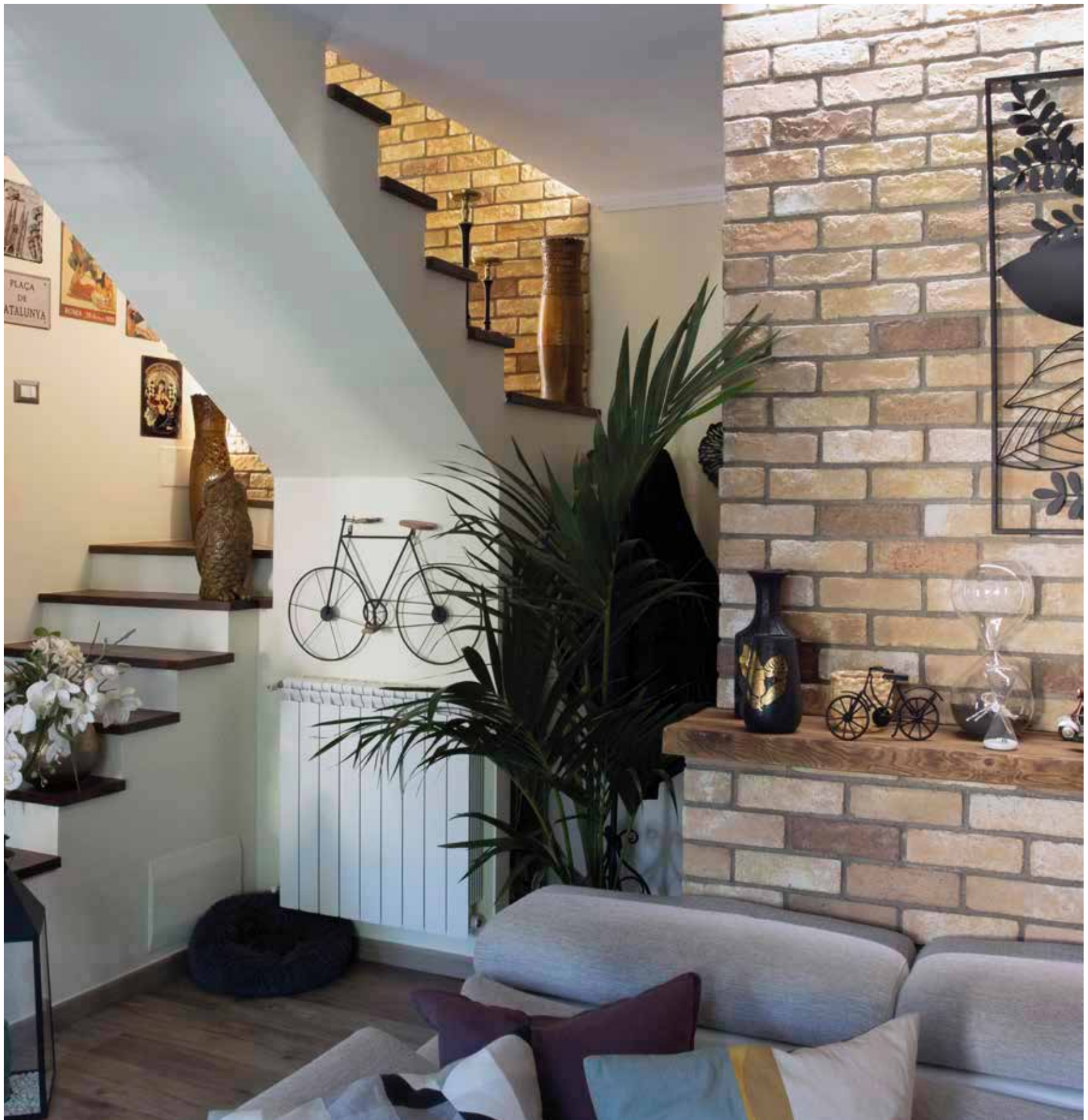



Rustico Flox



Rustico Iberis





Rustico Aster



Rustico Aster



# “ Antico Mattone

*Inspirato ai mattoni di argilla, la cui tradizione artigianale è stata custodita con dedizione nei conventi e nei monasteri, Antico Mattone è un mattone rustico dall'aspetto lineare e solido, che restituisce l'immagine di una concreta stabilità.*

*Inspired by clay bricks, whose artisan tradition has been preserved with dedication in convents and monasteries, Antico Mattone is a rustic brick which, with its linear and solid appearance, gives the image of concrete stability.*

*Inspiziert von den Ziegeln aus Ton, deren handwerkliche Tradition in Klöstern und Stiften mit Hingabe gepflegt wird, ist Antico Mattone ein rustikaler Ziegel mit einem linearen und kräftigem Erscheinungsbild, das den Eindruck konkreter Stabilität vermittelt.*

*Inspirée des briques d'argile, dont la tradition artisanale a été préservée avec dévouement dans les couvents et les monastères, Antico Mattone est une brique rustique à l'aspect linéaire et solide, qui renvoie l'image d'une véritable stabilité.*

# Antico Mattone



BIANCO



CENERE



GRIGIO FUMO



GIALLO



ARANCIO



ROSATO

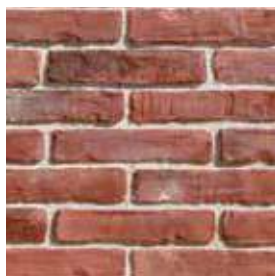

ROSSO

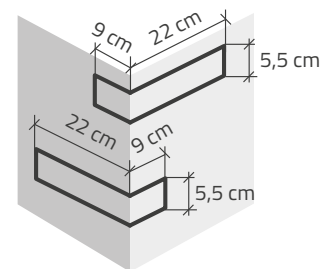
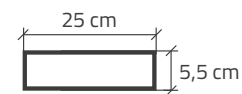

## SPECIFICHE DI PRODOTTO - PRODUCT SPECIFICATIONS ANGABEN ZUM PRODUKT - CARACTÉRISTIQUES DU PRODUIT

	DIMENSIONI DIMENSIONS ABMESSUNGEN DIMENSIONS	ALTEZZA HEIGHT HÖHE HAUTEUR	LUNGHEZZA LENGHT LÄNGE LONGUEUR	PESO A CONFEZIONE WEIGHT PER BOX GEWICHT/PACKUNG POIDS PAR BOÎTE	CONFEZIONE* PACKAGING PACKUNG BOÎTE	SPESSORE THICKNESS DICKE ÉPAISSEUR	POSA INSTALLATION VERLEGUNG POSE
<b>ELEMENTI PIANI</b> <b>FLAT ELEMENTS</b> <b>FLACHE ELEMENTE</b> <b>ÉLÉMENTS PLATS</b>	≈ 137,50 cm <sup>2</sup>	≈ 5,50 cm	≈ 25,00 cm	≈ 38,00 kg (32,00 kg/m <sup>2</sup> )	1,20 m <sup>2</sup> (36,00 m <sup>2</sup> /pallet)	2,50 - 3,00 cm	fugato grouted mit Fuge avec joint
<b>ELEMENTI ANGOLARI</b> <b>CORNER ELEMENTS</b> <b>ECKELEMENTE</b> <b>ÉLÉMENTS D'ANGLE</b>	-	≈ 5,50 cm	9,00 - 22,00 cm	≈ 22,00 kg	2,00 m (60,00 m/pallet)	2,50 - 3,00 cm	

RESA - YIELD - VERBRAUCH - RENDEMENT: ARREDOCOLLA 6-7 kg/m<sup>2</sup> / ARREDOSTUCCO 6-8 kg/m<sup>2</sup>

\*Giunto compreso | Joint included | einschließlich Fuge | joint compris ± 5%

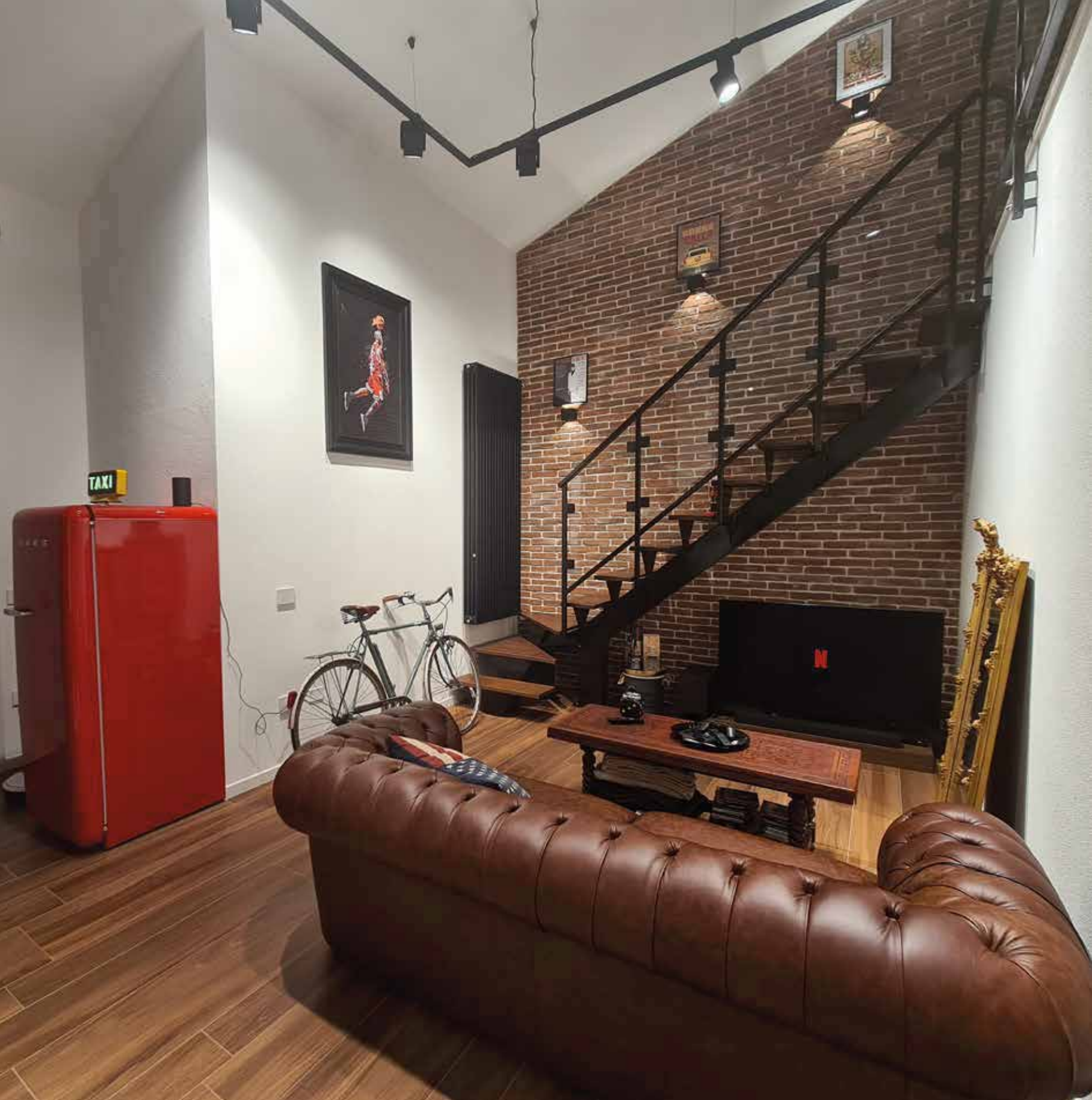







**Antico Mattone Rosso**



**Antico Mattone Cenere** | Progetto: Misuri Costruzione srl (PG)



**Antico Mattone Cenere** | Progetto: Misuri Costruzione srl (PG)



**Antico Mattone Cenere**



**Antico Mattone Giallo**



**Antico Mattone Rosato**



**Antico Mattone Rosato**





# “Lokon

*Lokon evoca le atmosfere incantate dei villaggi rurali del centro Europa. Con le sue forme scagliate e le superfici scalfite, come segnate dal tempo, Lokon si ispira all'aspetto aspro e aguzzo della pietra di montagna. La combinazione delle diverse tonalità proposte conferisce naturalità alle pareti, amalgamando l'opera dell'uomo ai tratti del paesaggio.*

*Lokon evokes the enchanted atmospheres of rural villages in the central Europe. With its jagged shapes and scratched surfaces, as if marked by the flowing time, Lokon is inspired by the harsh and pointed appearance of mountain stones. The combination of the different shades proposed gives naturalness to walls, thus blending the work of man with the landscape features.*

*Lokon beschwört die verzauberte Atmosphäre der ländlichen Dörfer Mitteleuropas herauf. Mit seinen zerklüfteten Formen und mit Kratzern durchzogenen Oberflächen, die von Zeit und dahinfließendem Leben gezeichnet sind, ist Lokon von der rauen und scharfen Beschaffenheit einiger Gesteine, die sich in Gebirgen finden. Die Kombination verschiedener Farbtöne, von Hellgrau über Braun bis hin zu Anthrazit, erzeugt vielfältige Farbeffekte und verleiht den Wänden Natürlichkeit, indem sie das Werk des Menschen mit den Merkmalen der Landschaft verschmilzt.*

*Lokon évoque les atmosphères enchantées des villages ruraux d'Europe Centrale. Avec ses formes écaillées et ses surfaces rayées, comme marquées par le temps, Lokon s'inspire de l'aspect dur et pointu de certaines pierres de montagne. La combinaison des différentes teintes proposées donne du naturel aux murs, mêlant le travail de l'homme aux traits du paysage.*

# Lokon



GRIGIO TERRA



GRIGIO ANTICO



GRIGIO CHIARO



MARRONE CHIARO



ANTRACITE

## SPECIFICHE DI PRODOTTO - PRODUCT SPECIFICATIONS - ANGABEN ZUM PRODUKT - CARACTÉRISTIQUES DU PRODUIT

	DIMENSIONI DIMENSIONS ABMESSUNGEN DIMENSIONS	ALTEZZA HEIGHT HÖHE HAUTEUR	LUNGHEZZA LENGHT LÄNGE LONGUEUR	PESO A CONFEZIONE WEIGHT PER BOX GEWICHT/PACKUNG POIDS PAR BOÎTE	CONFEZIONE* PACKAGING PACKUNG BOÎTE	SPESSORE THICKNESS DICKE ÉPAISSEUR	POSA INSTALLATION VERLEGUNG POSE
<b>ELEMENTI PIANI</b> <b>FLAT ELEMENTS</b> <b>FLACHE ELEMENTE</b> <b>ÉLÉMENTS PLATS</b>	da 30,00 cm <sup>2</sup> a 625,00 cm <sup>2</sup>	-	-	≈ 36,00 kg (45,00 kg/m <sup>2</sup> )	0,80 m <sup>2</sup> (24,00 m <sup>2</sup> /pallet)	2,00 - 6,50 cm	fugato grouted mit Fuge avec joint
<b>ELEMENTI ANGOLARI</b> <b>CORNER ELEMENTS</b> <b>ECKELEMENTE</b> <b>ÉLÉMENTS D'ANGLE</b>	-	da 5,00 cm <sup>2</sup> a 12,00 cm <sup>2</sup>	da 10,00 cm <sup>2</sup> a 30,00 cm <sup>2</sup>	≈ 20,00 kg	1,50 m (37,50 m/pallet)	2,00 - 6,50 cm	

RESA - YIELD - VERBRAUCH - RENDEMENT: ARREDOCOLLA 6-7 kg/m<sup>2</sup> / ARREDOSTUCCO 8-10 kg/m<sup>2</sup>

\*Giunto compreso | Joint included | einschließlich Fuge | joint compris ± 5%





















Lokon Marrone Chiaro





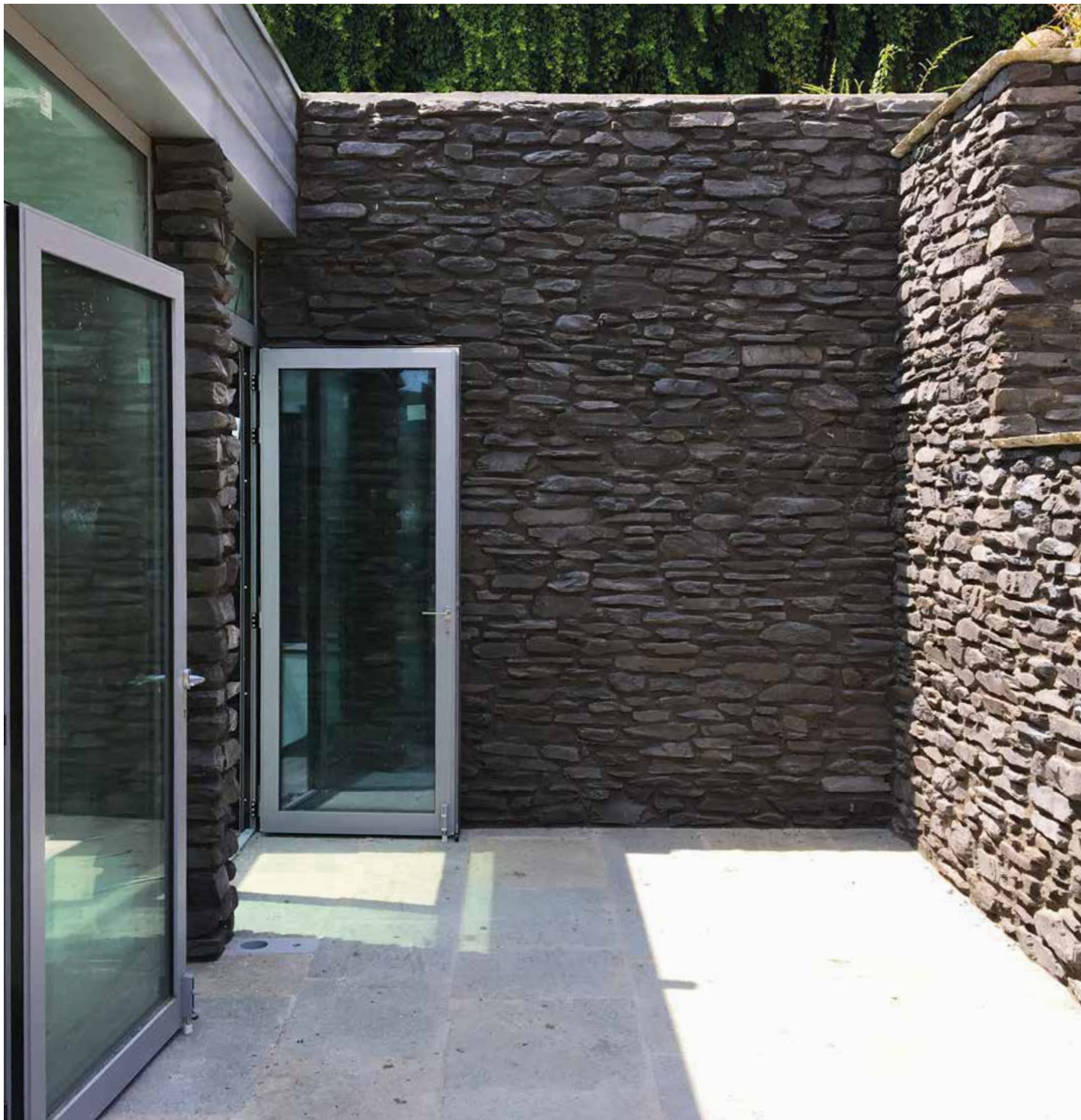



# “Olkaria

*Caratterizzata da forme irregolari, spigolose e sottili, Olkaria si ispira all'edilizia tradizionale della Renania, nella Germania occidentale. Una pietra che porta impresse le immagini incantate della Valle del Mosella, dove il fiume scorre in ampie anse tra pareti rocciose e pendii coperti dai vigneti di Riesling da cui si ottiene un vino fresco e profumato come la primavera.*

*Characterised by irregular, angular and thin shapes, Olkaria is inspired by the traditional building of the Rhineland, in western Germany. A stone carrying the enchanted images of the Moselle Valley, where the river flows in wide bends between rocky walls and slopes covered by Riesling vineyards from which a wine that is fresh, light and fragrant like spring is obtained.*

*Olkaria zeichnet sich durch unregelmäßige, kantige und subtile Formen aus und ist von der traditionellen Bauweise im Rheinland inspiriert. Ein Stein, der die bezaubernden Bilder des Moseltals trägt, wo der Fluss in weiten Schleifen zwischen Felswänden und mit Rieslingreben bewachsenen Hängen fließt, aus denen ein frischer, leichter und nach Frühling duftender Wein gewonnen wird.*

*Caractérisée par des formes irrégulières, anguleuses et fines, Olkaria s'inspire de la construction traditionnelle de la Rhénanie, en Allemagne de l'Ouest. Une pierre qui porte les images enchantées de la vallée de la Moselle, où la rivière coule dans de larges méandres entre des parois rocheuses et des pentes couvertes de vignobles de Riesling dont on obtient un vin frais, léger et parfumé comme le printemps.*

# Olkaria



CREMA



GRIGIO TERRA



GRIGIO ANTICO



TERRA



GRIGIO CHIARO



GRIGIO



GRIGIO MIX



ANTRACITE

## SPECIFICHE DI PRODOTTO - PRODUCT SPECIFICATIONS - ANGABEN ZUM PRODUKT - CARACTÉRISTIQUES DU PRODUIT

	DIMENSIONI DIMENSIONS ABMESSUNGEN DIMENSIONS	ALTEZZA HEIGHT HÖHE HAUTEUR	LUNGHEZZA LENGHT LÄNGE LONGUEUR	PESO A CONFEZIONE WEIGHT PER BOX GEWICHT/PACKUNG POIDS PAR BOÎTE	CONFEZIONE* PACKAGING PACKUNG BOÎTE	SPESSORE THICKNESS DICKE ÉPAISSEUR	POSA INSTALLATION VERLEGUNG POSE
<b>ELEMENTI PIANI</b> <b>FLAT ELEMENTS</b> <b>FLACHE ELEMENTE</b> <b>ÉLÉMENTS PLATS</b>	da 40,00 cm <sup>2</sup> a 500,00 cm <sup>2</sup>	-	-	≈ 36,00 kg (45,00 kg/m <sup>2</sup> )	0,80 m <sup>2</sup> (24,00 m <sup>2</sup> /pallet)	3,00 - 6,00 cm	fugato/ a secco grouted/ dry stacked
<b>ELEMENTI ANGOLARI</b> <b>CORNER ELEMENTS</b> <b>ECKELEMENTE</b> <b>ÉLÉMENTS D'ANGLE</b>	-	da 4,00 cm <sup>2</sup> a 10,00 cm <sup>2</sup>	da 5,50 cm <sup>2</sup> a 25,00 cm <sup>2</sup>	≈ 20,00 kg	1,50 m (45,00 m/pallet)	3,00 - 6,00 cm	mit Fuge/ trocken avec joint/ joint sec

RESA - YIELD - VERBRAUCH - RENDEMENT: ARREDOCOLLA 6-7 kg/m<sup>2</sup> / ARREDOSTUCCO 8-10 kg/m<sup>2</sup>

Per posa a secco prevedere nell'ordine un quantitativo di pietra maggiora di ≈ 15% | For dry stacked installation, the quantity of sane ordered should be increased by ≈ 15%  
Für die Trockenverlegung muss in der Bestellung eine Menge von ≈ 15% zusätzlich vorgesehen werden | Pour pose à sec, prévoir dans la commande une quantité de pierre majorée de ≈ 15%

\*Giunto compreso | Joint included | einschließlich Fuge | joint compris ± 5%























Olkaria Crema





Olkaria Grigio Chiaro



Olkaria Grigio Chiaro









# “Sakar

*Sakar è un rivestimento elegante, ma versatile, adatto a diversi stili architettonici: sottili elementi di pietra scagliata, armoniosamente combinati in moduli rettangolari di facile applicazione, che permettono di ottenere superfici dall'aspetto sminuzzato e irregolare. Sakar crea ambienti raffinati e atmosfere di classe, genuine e sofisticate, intime e mondane.*

*Sakar is an elegant yet versatile wall covering, suitable for different architectural styles: thin elements of jagged stone, harmoniously combined in easy-to-apply rectangular modules, which allow to obtain surfaces with a chipped and irregular appearance. Sakar creates refined environments and classy atmospheres which, at the same time, are genuine and sophisticated, intimate and worldly.*

*Sakar ist eine elegante und zugleich vielseitige Verkleidung, die sich für verschiedene architektonische Stile eignet: schmale, gemeißelte Steinelemente, die harmonisch in leicht zu verarbeitenden, rechteckigen Modulen kombiniert sind, ermöglichen Oberflächen mit einem kleinteiligen, unregelmäßigen Aussehen. Sakar verbindet die Sehnsucht nach Natürlichkeit mit zeitgenössischen Einrichtungstrends und schafft exquisite Umgebungen und stilvolle Atmosphären*

*Sakar est un revêtement mural élégant mais polyvalent, adapté à différents styles architecturaux: éléments élancés de pierre écaillée, harmonieusement combinés dans des modules rectangulaires faciles à appliquer, qui permettent d'obtenir des surfaces d'aspect éclaté et irrégulier. Sakar crée des environnements raffinés et des atmosphères classes, à la fois authentiques et sophistiquées, intimes et mondaines.*

# Sakar

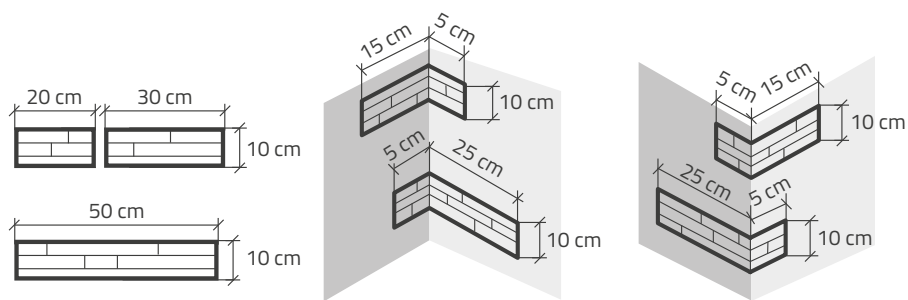

CENERE



NUVOLA



CAMEL



GRIGIO FUMO



BIANCO



CREMA



GRIGIO TERRA



AMBRA



GRIGIO CHIARO



ANTRACITE

## SPECIFICHE DI PRODOTTO - PRODUCT SPECIFICATIONS - ANGABEN ZUM PRODUKT - CARACTÉRISTIQUES DU PRODUIT

	DIMENSIONI DIMENSIONS ABMESSUNGEN DIMENSIONS	ALTEZZA HEIGHT HÖHE HAUTEUR	LUNGHEZZA LENGHT LÄNGE LONGUEUR	PESO A CONFEZIONE WEIGHT PER BOX GEWICHT/PACKUNG POIDS PAR BOÎTE	CONFEZIONE* PACKAGING PACKUNG BOÎTE	SPESSORE THICKNESS DICKE ÉPAISSEUR	POSA INSTALLATION VERLEGUNG POSE
<b>ELEMENTI PIANI</b> <b>FLAT ELEMENTS</b> <b>FLACHE ELEMENTE</b> <b>ÉLÉMENTS PLATS</b>	da 200,00 cm <sup>2</sup> a 500,00 cm <sup>2</sup>	≅ 10,00 cm	≅ 20,00 cm ≅ 30,00 cm ≅ 50,00 cm	≅ 23,00 kg (46,00 kg/m <sup>2</sup> )	0,50 m <sup>2</sup> (30,00 m <sup>2</sup> /pallet)	≅ 5,00 cm	a secco dry stacked trocken joint sec
<b>ANGOLO ESTERNO</b> <b>EXTERNAL CORNER</b> <b>AUSSENECKE</b> <b>ANGLE EXTERNE</b>	-	≅ 10,00 cm	5,00 cm - 15,00 cm 5,00 cm - 25,00 cm	≅ 15,00 kg	1,00 m (60,00 m/pallet)	≅ 5,00 cm	
<b>ANGOLO INTERNO</b> <b>INTERNAL CORNER</b> <b>INNENECKE</b> <b>ANGLE INTERNE</b>		≅ 10,00 cm	5,00 cm - 15,00 cm 5,00 cm - 25,00 cm	≅ 15,00 kg	1,00 m (60,00 m/pallet)	≅ 5,00 cm	

RESA - YIELD - VERBRAUCH - RENDEMENT: ARREDOCOLLA 6-7 kg/m<sup>2</sup>

\*Giunto compreso | Joint included | einschließlich Fuge | joint compris ± 5%















Sakar Caramel | Orsini Mood (AV)



Sakar Caramel | Orsini Mood (AV)

















Sakar Grigio Chiaro



Sakar Nuvola



# “Muria

*Listelli di pietra rettangolari, sottili e leggeri, dalla superficie liscia o frastagliata, composti in un mosaico sfalsato che crea sulle pareti un ricercato effetto di tridimensionalità. Utilizzato soprattutto nelle costruzioni dal design contemporaneo, Muria crea un delicato connubio tra ordine e complessità, ricercatezza e minimalismo: un rivestimento di classe per ambienti raffinati.*

*Rectangular, thin and light stone slats, with a smooth or jagged surface, composed of a staggered mosaic that creates a refined three-dimensional effect on the walls. Especially used in buildings with a contemporary design, Muria creates a delicate combination of order and complexity, refinement and minimalism: a classy covering for sophisticated environments.*

*Rechteckige, dünne und leichte Steinplatten mit glatter oder gezackter Oberfläche sind zusammengefügt zu einem Mosaik, das einen außergewöhnlichen dreidimensionalen Effekt an den Wänden erzeugt. Muria wird hauptsächlich in Gebäuden mit zeitgenössischem Design verwendet und schafft eine sanfte Kombination aus Ordnung und Komplexität, Raffinesse und Minimalismus: eine edle Verkleidung für elegante Räume.*

*Listels en pierre rectangulaires, fins et légers, avec une surface lisse ou irrégulière, composés d'une mosaïque décalée qui crée un effet tridimensionnel raffiné sur les murs. Utilisé surtout dans les constructions au design contemporain, Muria crée une délicate combinaison d'ordre et de complexité, de recherche et de minimalisme: un revêtement classe pour des environnements raffinés.*

# Muria



CREMA



SABBIA



GRIGIO FUMO



GRIGIO CHIARO

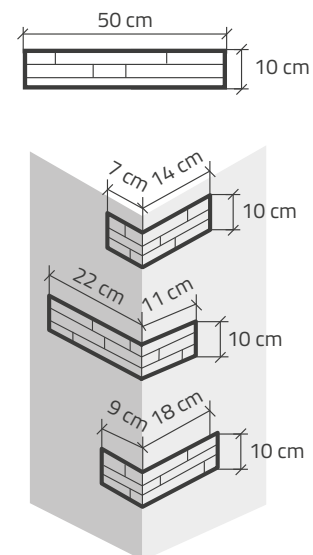

Nuovo Formato - Nuovi Colori | New size - New colors  
Neues Format - Neue Farben | Nouveau format - Nouvelles couleurs

## SPECIFICHE DI PRODOTTO - PRODUCT SPECIFICATIONS - ANGABEN ZUM PRODUKT - CARACTÉRISTIQUES DU PRODUIT

	DIMENSIONI DIMENSIONS ABMESSUNGEN DIMENSIONS	ALTEZZA HEIGHT HÖHE HAUTEUR	LUNGHEZZA LENGTH LÄNGE LONGUEUR	PESO A CONFEZIONE WEIGHT PER BOX GEWICHT/PACKUNG POIDS PAR BOÎTE	CONFEZIONE* PACKAGING PACKUNG BOÎTE	SPESSORE THICKNESS DICKE ÉPAISSEUR	POSA INSTALLATION VERLEGUNG POSE
<b>ELEMENTI PIANI</b> <b>FLAT ELEMENTS</b> <b>FLACHE ELEMENTE</b> <b>ÉLÉMENTS PLATS</b>	≈ 500,00 cm <sup>2</sup>	≈ 10,00 cm	≈ 50,00 cm	≈ 18,00 kg (30,00 kg)	≈ 0,60 m <sup>2</sup> (36,00 m <sup>2</sup> /pallet)	1,5 - 3,00 cm	a secco dry stacked trocken joint sec
<b>ELEMENTI ANGOLARI</b> <b>CORNER ELEMENTS</b> <b>ECKELEMENTE</b> <b>ÉLÉMENTS D'ANGLE</b>	-	≈ 10,00 cm	da 7,00 cm a 22,00 cm	≈ 11,00 kg	≈ 1,00 m <sup>2</sup> (60,00 m <sup>2</sup> /pallet)	1,5 - 3,00 cm	

RESA - YIELD - VERBRAUCH - RENDEMENT: ARREDOCOLLA 6-7 kg/m<sup>2</sup>





# “Kalos

*Tutto il fascino del legno in un rivestimento a listelli combinati in moduli che riproducono la straordinaria varietà delle sfumature naturali. Kalos si distingue per le sue superfici irregolari impreziosite da spaccature e dettagli che sorprendono la vista e il tatto, creando atmosfere materiche, calde e accoglienti anche negli ambienti dal carattere più contemporaneo.*

*All the charm of wood in a cladding with strips combined in modules reproducing the extraordinary variety of natural nuances. Kalos stands out for its irregular surfaces embellished with cracks and details that surprise eyes and touch, thus creating material, warm and welcoming atmospheres even within more contemporary environments.*

*Der ganze Charme von Holz in einer Verkleidung aus Leisten, kombiniert in Modulen, die die außergewöhnliche Vielfalt der natürlichen Farbtöne wiedergeben. Kalos zeichnet sich durch seine unregelmäßigen Oberflächen aus, die mit Fugen und Details verziert sind, die das Auge und den Tastsinn überraschen und selbst in modernsten Umgebungen eine greifbare, warme und gemütliche Atmosphäre schaffen.*

*Tout le charme du bois dans un revêtement à listels réunis en modules reproduisant l'extraordinaire variété des nuances naturelles. Kalos se distingue par ses surfaces irrégulières agrémentées de craquelures et de détails qui surprennent l'œil et le toucher, créant des atmosphères matérielles, chaleureuses et accueillantes, même dans des environnements au caractère plus contemporain.*

# Kalos

ELEMENTI PIANI | FLAT ELEMENTS  
FLACHE ELEMENTE | ÉLÉMENTS PLATS

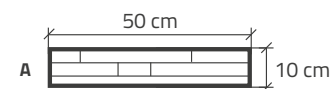

ELEMENTI ANGOLARI | CORNER ELEMENTS  
ECKELEMENTE | ÉLÉMENTS D'ANGLE

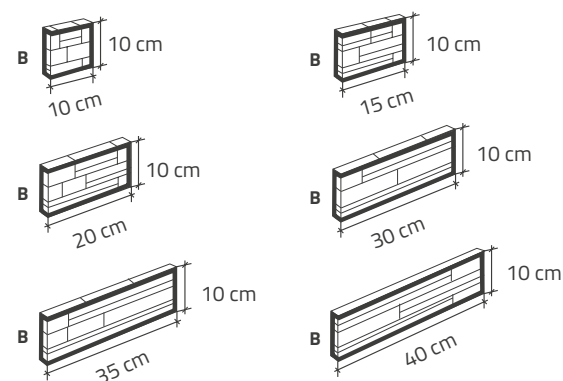

CARAMEL



MOKA



CENERE



ROVERE



GRIGIO FUMO



VANILLA

SCHEMA DI POSA | LAYING PATTERN  
ANBAUSCHEMA | SCHÉMA DE POSE

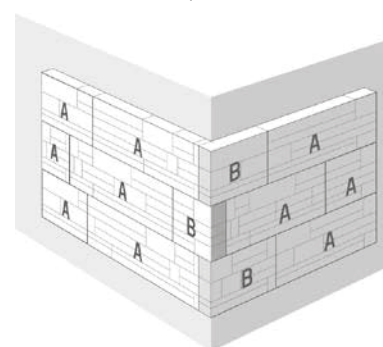

## SPECIFICHE DI PRODOTTO - PRODUCT SPECIFICATIONS - ANGABEN ZUM PRODUKT - CARACTÉRISTIQUES DU PRODUIT

	DIMENSIONI DIMENSIONS ABMESSUNGEN DIMENSIONS	ALTEZZA HEIGHT HÖHE HAUTEUR	LUNGHEZZA LENGTH LÄNGE LONGUEUR	PESO A CONFEZIONE WEIGHT PER BOX GEWICHT/PACKUNG POIDS PAR BOÎTE	CONFEZIONE* PACKAGING PACKUNG BOÎTE	SPESSORE THICKNESS DICKE ÉPAISSEUR	POSA INSTALLATION VERLEGUNG POSE
<b>ELEMENTI PIANI FLAT ELEMENTS FLACHE ELEMENTE ÉLÉMENTS PLATS</b>	500,00 cm <sup>2</sup>	≈ 10,00 cm	≈ 50,00 cm	≈ 18,00 kg (30,00 kg/m <sup>2</sup> )	0,60 m <sup>2</sup> (36,00 m <sup>2</sup> /pallet)	≈ 3,00 cm	a secco dry stacked trocken joint sec
<b>ELEMENTI ANGOLARI CORNER ELEMENTS ECKELEMENTE ÉLÉMENTS D'ANGLE</b>		≈ 10,00 cm	≈ 10,00 cm ≈ 15,00 cm ≈ 20,00 cm ≈ 30,00 cm ≈ 35,00 cm ≈ 40,00 cm	≈ 18,00 kg	2,40 m (144,00 m <sup>2</sup> /pallet)	≈ 3,00 cm	

RESA - YIELD - VERBRAUCH - RENDEMENT: ARREDOCOLLA 6-7 kg/m<sup>2</sup>

\*Giunto compreso | Joint included | einschließlich Fuge | joint compris ± 5%









**Kalos Cenere**



**Kalos Caramel**



**Kalos Grigio Fumo**

**Kalos Caramel**



# “Cervino Panel

*Nata dalle stesse ispirazioni di Cervino, questa pietra è già fornita in forma di pannello che ne facilita estremamente la posa. Questa semplificazione non intacca la sua resa estetica che richiama lo stile delle baite di montagna e l'architettura essenziale dei villaggi alpini, dove la natura selvaggia si riflette sulle superfici spigolose e irregolari dei muri costruiti dall'uomo.*

*Originated from the same inspirations as Cervino, this stone is already supplied in the form of a panel which makes its laying extremely easy. Such facilitation does not affect its aesthetic rendering which recalls the style of mountain huts and the essential architecture of alpine villages, where wild nature is reflected on the angular and irregular surfaces of man-made walls.*

*Dieser Stein, der aus denselben Inspirationen wie Cervino entstanden ist, wird bereits in Form von Platten geliefert und ist daher sehr einfach zu verlegen. Diese Vereinfachung wirkt sich nicht auf die ästhetische Gestaltung aus, die an den Stil der Berghütten und die wesentliche Architektur der Alpendörfer erinnert, wo sich die wilde Natur in den kantigen und unregelmäßigen Oberflächen der von Menschenhand geschaffenen Mauern widerspiegelt.*

*Née des mêmes inspirations que Cervino, cette pierre est déjà fournie sous forme de panneau, ce qui la rend extrêmement facile à poser. Cette simplification n'affecte pas son rendu esthétique qui rappelle le style des cabanes de montagne et l'architecture essentielle des villages alpins, où la nature sauvage se reflète sur les surfaces anguleuses et irrégulières des murs construits par l'homme.*

# Cervino Panel

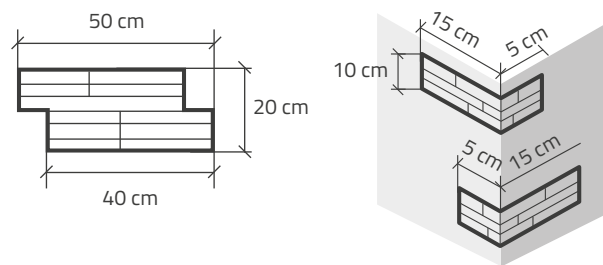

BIANCO ANTICO



GRIGIO ANTICO



NUVOLA



MARRONE CHIARO



CENERE

## A SCHEMA DI POSA | LAYING PATTERN ANBAUSCHEMA | SCHÉMA DE POSE

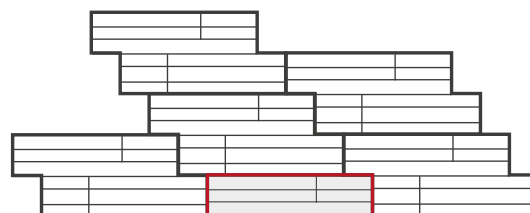

## PEZZO SPECIALE | SPECIAL PIECE SONDERSTÜCK | PIÈCE SPÉCIAL

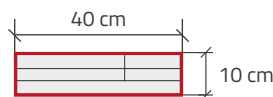

## B SCHEMA DI POSA | LAYING PATTERN ANBAUSCHEMA | SCHÉMA DE POSE

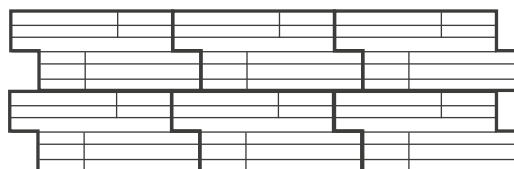

## SPECIFICHE DI PRODOTTO - PRODUCT SPECIFICATIONS - ANGABEN ZUM PRODUKT - CARACTÉRISTIQUES DU PRODUIT

	DIMENSIONI DIMENSIONS ABMESSUNGEN DIMENSIONS	ALTEZZA HEIGHT HÖHE HAUTEUR	LUNGHEZZA LENGHT LÄNGE LONGUEUR	PESO A CONFEZIONE WEIGHT PER BOX GEWICHT/PACKUNG POIDS PAR BOÎTE	CONFEZIONE* PACKAGING PACKUNG BOÎTE	SPESSORE THICKNESS DICKE ÉPAISSEUR	POSA INSTALLATION VERLEGUNG POSE
<b>ELEMENTI PIANI FLAT ELEMENTS FLACHE ELEMENTE ÉLÉMENTS PLATS</b>	≈ 800,00 cm <sup>2</sup>	≈ 20,00 cm	≈ 50,00 cm	≈ 21,00 kg (68,00 kg/m <sup>2</sup> )	0,32 m <sup>2</sup> (19,20 m <sup>2</sup> /pallet)	3,00 - 6,00 cm	a secco dry stacked trocken joint sec
<b>ELEMENTI ANGOLARI CORNER ELEMENTS ECKELEMENTE ÉLÉMENTS D'ANGLE</b>		≈ 10,00 cm	5,00 - 15,00 cm	≈ 25,00 kg	1,00 m (60,00 m/pallet)	3,00 - 6,00 cm	
<b>PEZZO SPECIALE SPECIAL PIECE SONDERSTÜCK PIÈCE SPÉCIAL</b>		≈ 10,00 cm	≈ 40,00 cm	≈ 21,00 kg (68,00 kg/m <sup>2</sup> )	0,32 m <sup>2</sup> (Nr.8)	3,00 - 6,00 cm	

RESA - YIELD - VERBRAUCH - RENDEMENT: ARREDOCOLLA 6-7 kg/m<sup>2</sup>







# “Madera

*Forme irregolari e superfici scolpite caratterizzano questi elementi tagliati in profili spaccati di formato medio-grande, ispirati alla pietra granitica delle isole vulcaniche nell'Oceano Atlantico. Con la sua personalità, Madera rende omaggio alla potenza generatrice della terra ed evoca un passato remotissimo che risale fino alla creazione del pianeta.*

*Irregular shapes and sculpted surfaces characterise these elements cut into split profiles of medium-large size, inspired by the granite stone of the volcanic islands in the Atlantic Ocean. Thanks to its charisma, Madera pays homage to the generating power of earth and evokes a very remote past that dates back to the creation of the planet.*

*Unregelmäßige Formen und gemeißelte Oberflächen kennzeichnen diese in mittelgroße Spaltprofile geschnittenen Elemente, die vom Granitgestein vulkanischer Inseln im Atlantik inspiriert sind. Mit den unverwechselbaren Eigenschaften ist Madeira eine Hommage an die Schöpfungskraft der Erde und beschwört eine sehr ferne Vergangenheit herauf, die bis zur Erschaffung des Planeten zurückreicht.*

*Des formes irrégulières et des surfaces sculptées caractérisent ces éléments découpés en profils fendus de taille moyenne à grande, inspirés de la pierre granitique des îles volcaniques de l'océan Atlantique. Avec sa personnalité, Madera rend hommage au pouvoir générateur de la terre et évoque un passé très lointain qui remonte à la création de la planète.*

# Madera



CREMA



GRIGIO CHIARO



TERRA

## SPECIFICHE DI PRODOTTO - PRODUCT SPECIFICATIONS - ANGABEN ZUM PRODUKT - CARACTÉRISTIQUES DU PRODUIT

	DIMENSIONI DIMENSIONS ABMESSUNGEN DIMENSIONS	ALTEZZA HEIGHT HÖHE HAUTEUR	LUNGHEZZA LENGHT LÄNGE LONGUEUR	PESO A CONFEZIONE WEIGHT PER BOX GEWICHT/PACKUNG POIDS PAR BOÎTE	CONFEZIONE* PACKAGING PACKUNG BOÎTE	SPESSORE THICKNESS DICKE ÉPAISSEUR	POSA INSTALLATION VERLEGUNG POSE
<b>ELEMENTI PIANI</b> <b>FLAT ELEMENTS</b> <b>FLACHE ELEMENTE</b> <b>ÉLÉMENTS PLATS</b>	da 70,00 cm <sup>2</sup> a 1500,00 cm <sup>2</sup>	-	-	≈ 18,00 kg (36,00 kg/m <sup>2</sup> )	0,50 m <sup>2</sup> (24,00 m <sup>2</sup> /pallet)	2,50 - 5,00 cm	fugato grouted mit Fuge avec joint
<b>ELEMENTI ANGOLARI</b> <b>CORNER ELEMENTS</b> <b>ECKELEMENTE</b> <b>ÉLÉMENTS D'ANGLE</b>	-	da 14,00 cm a 33,00 cm	da 5,00 cm a 20,00 cm	≈ 14,00 kg	1,00 m (48,00 m/pallet)	2,50 - 5,00 cm	

RESA - YIELD - VERBRAUCH - RENDEMENT: ARREDOCOLLA 6-7 kg/m<sup>2</sup> / ARREDOSTUCCO 8-10 kg/m<sup>2</sup>

\*Giunto compreso | Joint included | einschließlich Fuge | joint compris ± 5%







# “Milos

*Piccole fenditure alternate a parti levigate impreziosiscono le superfici eterogenee degli elementi rettangolari di Milos, creando sulle pareti giochi di luce e d'ombra dall'effetto ipnotico. Questa pietra da un lato ricorda le antiche murature a secco, dall'altro evoca le atmosfere caleidoscopiche del centro America.*

*Small cracks alternating with smooth parts embellish the heterogeneous surfaces of the rectangular elements of Milos, thus creating hypnotic effects of light and shadow on the walls. On the one hand, this stone recalls the ancient dry walls while, on the other, it evokes the kaleidoscopic atmospheres of Central America.*

*Kleine Risse, die sich mit polierten Stellen abwechseln, verschönern die heterogenen Oberflächen der rechteckigen Elemente von Milos und erzeugen an den Wänden Licht- und Schattenspiele mit hypnotischer Wirkung. Einerseits erinnert dieser Stein an alte Stadtmauern, andererseits an die bunte Atmosphäre Mittelamerikas, wo das Leben in einem Strudel aus intensiven.*

*De petites fissures alternées avec des parties lisses embellissent les surfaces hétérogènes des éléments rectangulaires de Milos, créant des effets hypnotiques de lumière et d'ombre sur les murs. D'une part, cette pierre rappelle les anciennes maçonneries à pierres sèches, d'autre part, elle évoque les atmosphères kaléidoscopiques de l'Amérique centrale.*

# Milos



MARRONE CHIARO



GRIGIO CHIARO

## SPECIFICHE DI PRODOTTO - PRODUCT SPECIFICATIONS - ANGABEN ZUM PRODUKT - CARACTÉRISTIQUES DU PRODUIT

	DIMENSIONI DIMENSIONS ABMESSUNGEN DIMENSIONS	ALTEZZA HEIGHT HÖHE HAUTEUR	LUNGHEZZA LENGHT LÄNGE LONGUEUR	PESO A CONFEZIONE WEIGHT PER BOX GEWICHT/PACKUNG POIDS PAR BOÎTE	CONFEZIONE* PACKAGING PACKUNG BOÎTE	SPESSORE THICKNESS DICKE ÉPAISSEUR	POSA INSTALLATION VERLEGUNG POSE
<b>ELEMENTI PIANI</b> <b>FLAT ELEMENTS</b> <b>FLACHE ELEMENTE</b> <b>ÉLÉMENTS PLATS</b>	da 70,00 cm <sup>2</sup> a 800,00 cm <sup>2</sup>	-	-	≈ 34,00 kg (56,00 kg/m <sup>2</sup> )	0,60 m <sup>2</sup> (18,00 m <sup>2</sup> /pallet)	4,00 - 8,00 cm	fugato/ a secco grouted/ dry stacked
<b>ELEMENTI ANGOLARI</b> <b>CORNER ELEMENTS</b> <b>ECKELEMENTE</b> <b>ÉLÉMENTS D'ANGLE</b>	-	7,00 - 15,00 cm	5,00 - 28,00 cm	≈ 29,00 kg	1,50 m (45,00 m/pallet)	4,00 - 8,00 cm	mit Fuge/ trocken avec joint/ joint sec

RESA - YIELD - VERBRAUCH - RENDEMENT: ARREDOCOLLA 6-7 kg/m<sup>2</sup> / ARREDOSTUCCO 8-10 kg/m<sup>2</sup>

Per posa a secco prevedere nell'ordine un quantitativo di pietra maggiora di ≈ 15% | For dry stacked installation, the quantity of sane ordered should be increased by ≈ 15%  
Für die Trockenverlegung muss in der Bestellung eine Menge von ≈ 15% zusätzlich vorgesehen werden | Pour pose à sec, prévoir dans la commande une quantité de pierre majorée de ≈ 15%

\*Giunto compreso | Joint included | einschließlich Fuge | joint compris ± 5%

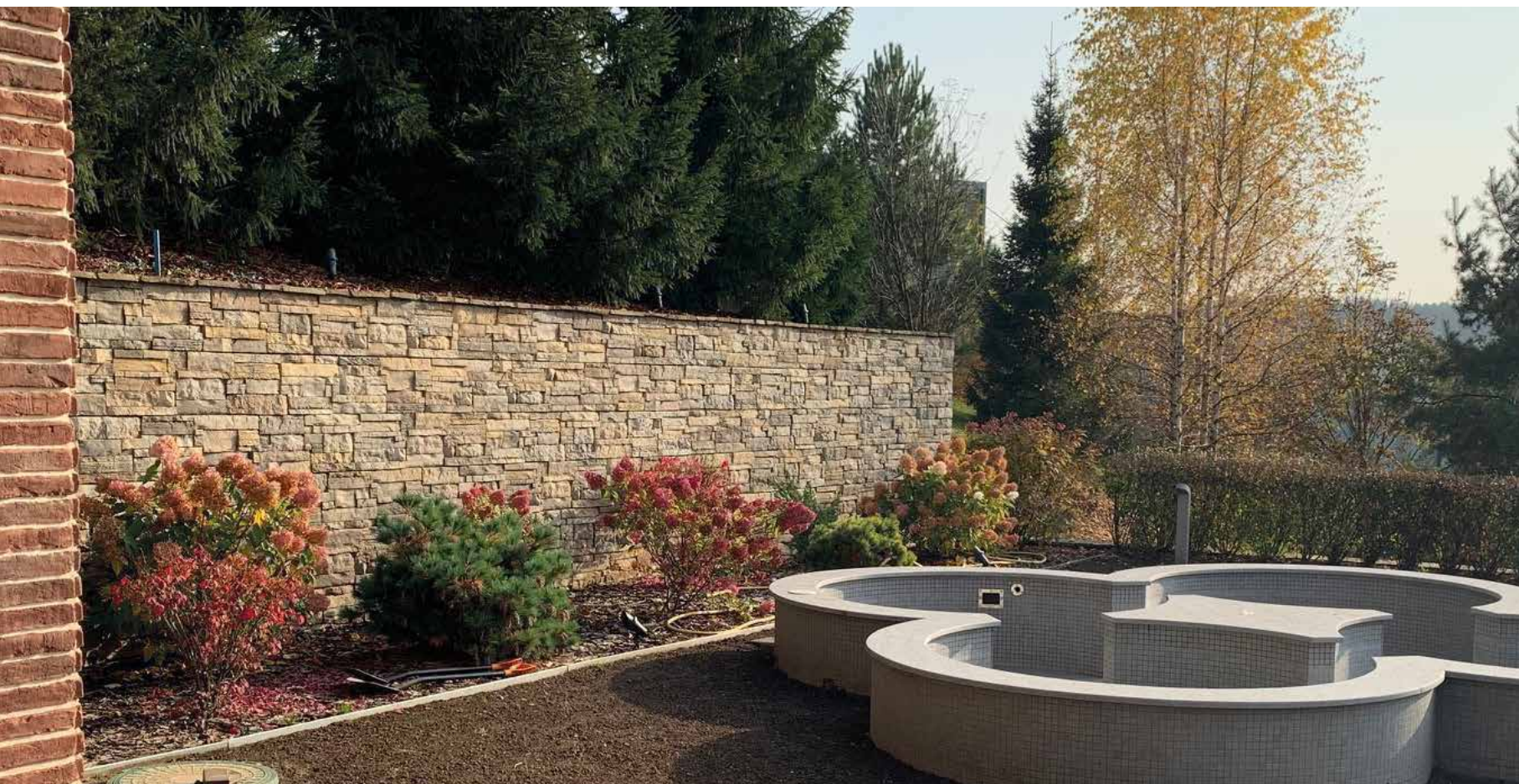





# “ Belmonte

*Ispirata ai borghi delle colline piemontesi, Belmonte si presenta con elementi squadrati dal taglio regolare e una superficie levigata, contraddistinta da sfumature che vanno dal crema al rosato al grigio. Una pietra che evoca l'atmosfera placida dei piccoli centri adagiati sui colli, dove l'opera dell'uomo si staglia umile sulle curve dolci della natura.*

*Inspired by the villages of the hills of Piedmont, Belmonte shows itself with squared elements, having a regular cut and a smooth surface, characterised by nuances ranging from cream to pink to grey. A stone evoking the placid atmosphere of small villages lying on the hills, where the work of man humbly stands out against the gentle curves of nature.*

*Inspiziert von den Dörfern der piemontesischen Hügellandschaft, zeichnet sich Belmonte durch quadratische Elemente mit regelmäßigem Schnitt und polierter Oberfläche aus, die von cremefarbenen, roséfarbenen und grauen Tönen geprägt sind. Ein Stein, der an die ruhige Atmosphäre von kleinen Städten in den Hügeln erinnert, wo sich das Werk des Menschen bescheiden von den sanften Kurven der Natur abhebt.*

*Inspirée des villages des collines du Piémont, Belmonte se présente avec des éléments carrés à la coupe régulière et à la surface lisse, caractérisés par des nuances allant du crème au rosé en passant par le gris. Une pierre qui évoque l'atmosphère placide des petites villes situées sur les collines, où le travail de l'homme se tient humblement sur les courbes douces de la nature.*

# Belmonte



## COMPOSIZIONE COMPOSITION MISHUNG COMPOSITION

SANTIAGO terra: 20%

TEIDE terra: 20%

SANTIAGO grigio terra: 20%

TEIDE grigio terra: 20%

ARENAL marrone scuro: 10%

SANTIAGO grigio chiaro: 10%

### SPECIFICHE DI PRODOTTO - PRODUCT SPECIFICATIONS - ANGABEN ZUM PRODUKT - CARACTÉRISTIQUES DU PRODUIT

	DIMENSIONI DIMENSIONS ABMESSUNGEN DIMENSIONS	ALTEZZA HEIGHT HÖHE HAUTEUR	LUNGHEZZA LENGHT LÄNGE LONGUEUR	PESO A CONFEZIONE WEIGHT PER BOX GEWICHT/PACKUNG POIDS PAR BOÎTE	CONFEZIONE* PACKAGING PACKUNG BOÎTE	SPESSORE THICKNESS DICKE ÉPAISSEUR	POSA INSTALLATION VERLEGUNG POSE
<b>ELEMENTI PIANI</b> <b>FLAT ELEMENTS</b> <b>FLACHE ELEMENTE</b> <b>ÉLÉMENTS PLATS</b>	da 30,00 cm <sup>2</sup> a 1225,00 cm	-	-	≅ 41,00 kg	1,00 m <sup>2</sup> (25,00 m <sup>2</sup> /pallet)	2,00 - 5,00 cm	fugato grouted mit Fuge avec joint
<b>ELEMENTI ANGOLARI</b> <b>CORNER ELEMENTS</b> <b>ECKELEMENTE</b> <b>ÉLÉMENTS D'ANGLE</b>	-	da 8,00 cm a 36,00 cm	da 8,00 cm a 28,00 cm	≅ 30,00 kg	2,00 m (60,00 m/pallet)	2,00 - 5,00 cm	

RESA - YIELD - VERBRAUCH - RENDEMENT: ARREDOCOLLA 6-7 kg/m<sup>2</sup> / ARREDOSTUCCO 8-10 kg/m<sup>2</sup>

\*Giunto compreso | Joint included | einschließlich Fuge | joint compris ± 5%















# “Misto Umbro

*Una commistione tra l'arenaria, con la sua superficie terrigna erosa dal tempo, e l'umile compostezza del mattone: Misto Umbro ripropone l'antica edilizia dei casolari del centro Italia, dove si costruiva con il materiale a disposizione, trasformando la casualità in armonia creativa, espressione di genuina bellezza.*

*A mixture of sandstone, with its earthy surface eroded by time, and the humble composure of brick: Misto Umbro re-proposes the ancient building of farmhouses in central Italy, where everything was built with any material available, thus turning randomness into creative harmony, an expression of genuine beauty.*

*Eine Mischung aus Sandstein mit seiner erdigen, von der Zeit erodierten Oberfläche und der bescheidenen Festigkeit von Backstein: Misto Umbro erinnert an die antike Bauweise der Bauernhäuser in Mittelitalien, wo die Menschen mit dem vorhandenen Material bauten und den Zufall in kreative Harmonie verwandelten, ein Ausdruck echter Schönheit.*

*Un mélange entre le grès, avec sa surface terreuse érodée par le temps, et le calme humble de la brique: Misto Umbro propose à nouveau l'ancien bâtiment des fermes de l'Italie centrale, où l'on construisait avec les matériaux disponibles, transformant le hasard en harmonie créative, expression d'une beauté authentique.*

# Misto Umbro



SABBIA

**COMPOSIZIONE**  
**COMPOSITION**  
**MISHUNG**  
**COMPOSITION**

ARENAL sabbia: 70%  
ARENAL marrone scuro: 10%  
ARENAL grigio terra: 10%  
ANTICO MATTONE rosato: 10%



GRIGIO TERRA

**COMPOSIZIONE**  
**COMPOSITION**  
**MISHUNG**  
**COMPOSITION**

ARENAL grigio terra: 80%  
ARENAL grigio chiaro: 10%  
ANTICO MATTONE rosato: 10%



BIANCO TERRA

**COMPOSIZIONE**  
**COMPOSITION**  
**MISHUNG**  
**COMPOSITION**

ARENAL bianco terra: 80%  
TAOS grigio terra: 10%  
ANTICO MATTONE rosato: 10%



CREMA

**COMPOSIZIONE**  
**COMPOSITION**  
**MISHUNG**  
**COMPOSITION**

ARENAL crema: 60%  
ARENAL grigio chiaro: 10%  
SANTIAGO grigio terra: 20%  
TEIDE bianco: 5%  
ANTICO MATTONE rosato: 5%

**SPECIFICHE DI PRODOTTO - PRODUCT SPECIFICATIONS - ANGABEN ZUM PRODUKT - CARACTÉRISTIQUES DU PRODUIT**

	DIMENSIONI DIMENSIONS ABMESSUNGEN DIMENSIONS	ALTEZZA HEIGHT HÖHE HAUTEUR	LUNGHEZZA LENGHT LÄNGE LONGUEUR	PESO A CONFEZIONE WEIGHT PER BOX GEWICHT/PACKUNG POIDS PAR BOÎTE	CONFEZIONE* PACKAGING PACKUNG BOÎTE	SPESSORE THICKNESS DICKE ÉPAISSEUR	POSA INSTALLATION VERLEGUNG POSE
<b>ELEMENTI PIANI</b> <b>FLAT ELEMENTS</b> <b>FLACHE ELEMENTE</b> <b>ÉLÉMENTS PLATS</b>	da 30,00 cm <sup>2</sup> a 1225,00 cm <sup>2</sup>	-	-	≈ 36,00 kg	1,00 m <sup>2</sup> (25,00 m <sup>2</sup> /pallet)	2,00 - 5,00 cm	fugato grouted mit Fuge avec joint
<b>ELEMENTI ANGOLARI</b> <b>CORNER ELEMENTS</b> <b>ECKELEMENTE</b> <b>ÉLÉMENTS D'ANGLE</b>	-	da 5,50 cm a 36,00 cm	da 8,00 cm a 28,00 cm	≈ 25,00 kg	2,00 m (60,00 m/pallet)	2,00 - 5,00 cm	

**RESA - YIELD - VERBRAUCH - RENDEMENT: ARREDOCOLLA 6-7 kg/m<sup>2</sup> / ARREDOSTUCCO 8-10 kg/m<sup>2</sup>**

\*Giunto compreso | Joint included | einschließlich Fuge | joint compris ± 5%



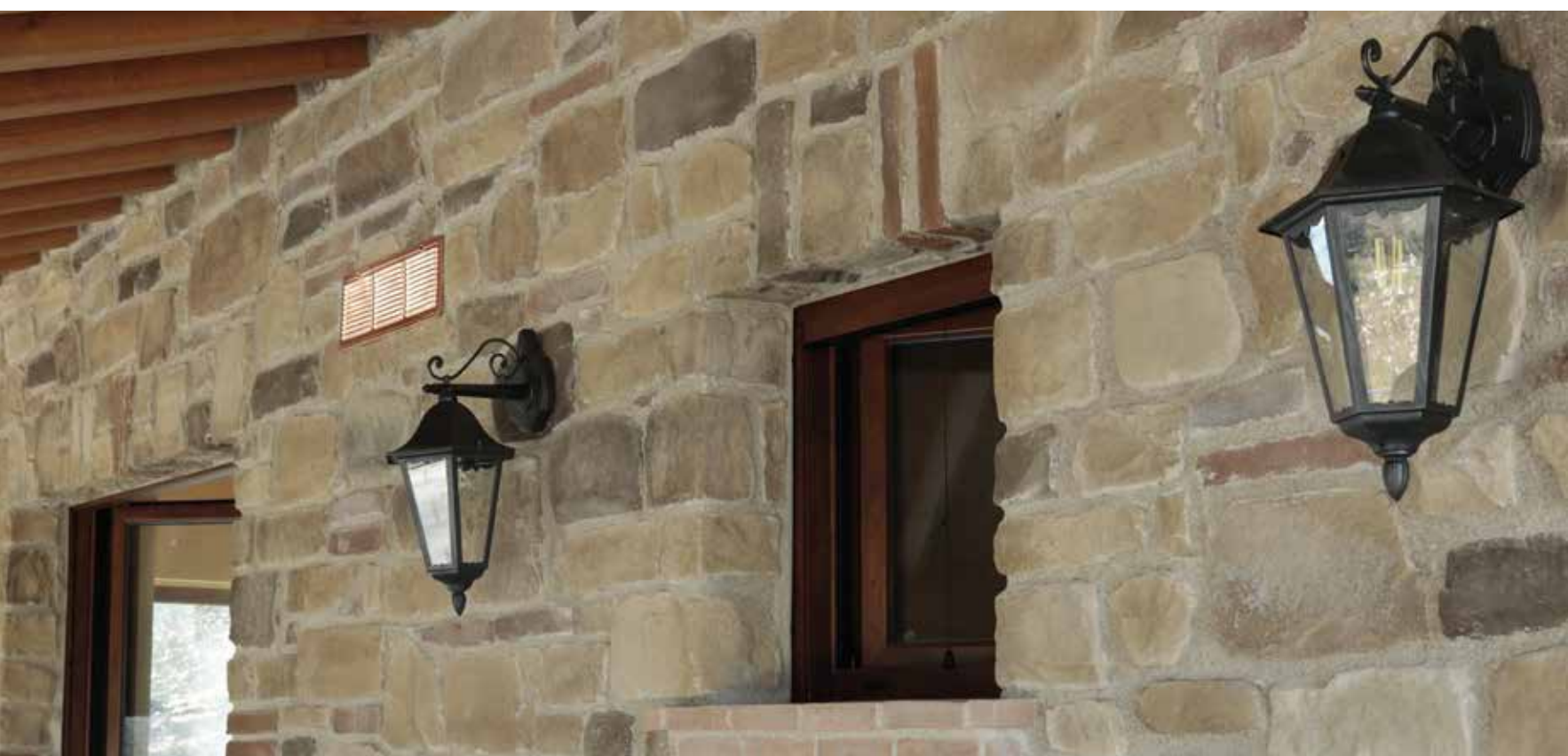







**Misto Umbro Sabbia**



**Misto Umbro Grigio Terra**

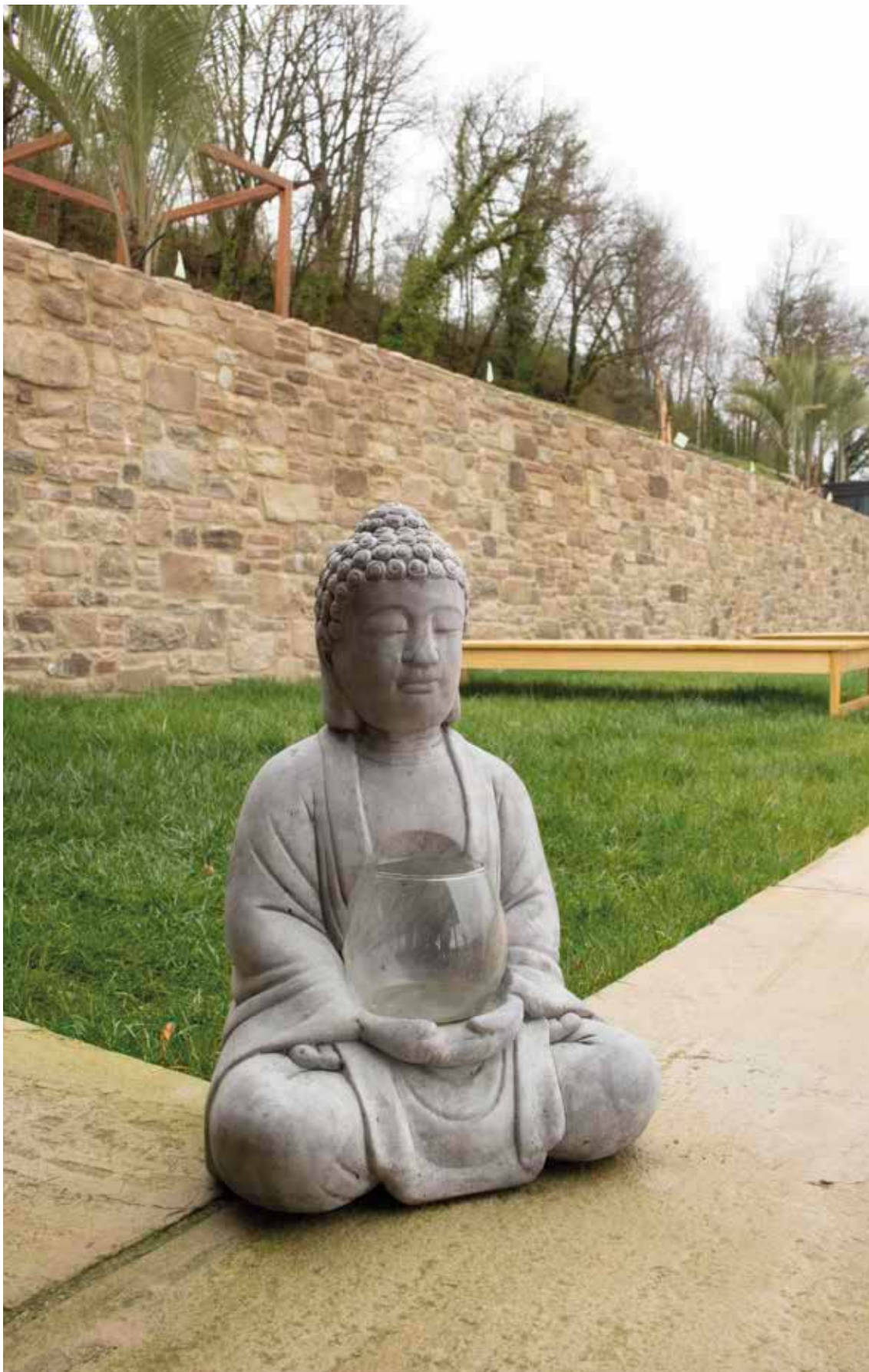

**Misto Umbro Sabbia**





# “Misto Campagna

*Sassi tondi e levigati incontrano la ruvidezza dell'arenaria e la linearità del mattone creando combinazioni di tonalità e forme che sembrano fondersi con l'ambiente naturale. Così Misto Campagna rievoca l'antica essenza del costruire con i materiali offerti dalla natura, portando alle mente paesaggi rurali e atmosfere d'altri tempi.*

*Round and smooth stones meet the roughness of sandstone and the linearity of brick, thus creating combinations of nuances and shapes that seem to blend with the natural environment. Therefore Misto Campagna evokes the ancient essence of building through materials offered by nature, thus bringing to mind rural landscapes and atmospheres of other times.*

*Runde, geschliffene Steine treffen auf die Rauheit des Sandsteins und die Geradlinigkeit des Ziegelsteins und schaffen Kombinationen von Farbtönen und Formen, die mit der natürlichen Umgebung zu verschmelzen scheinen. So erinnert Misto Campagna an das antike Wesen des Bauens mit den von der Natur angebotenen Materialien, an ländliche Landschaften und die Atmosphäre vergangener Tage.*

*Les pierres rondes et lisses rencontrent la rugosité du grès et la linéarité de la brique, créant des combinaisons de nuances et de formes qui semblent se fondre dans l'environnement naturel. Ainsi, Misto Campagna évoque l'essence ancienne de la construction avec les matériaux offerts par la nature, évoquant des paysages ruraux et des atmosphères d'autrefois.*

# Misto Campagna



GRIGIO TERRA

**COMPOSIZIONE**  
**COMPOSITION**  
**MISHUNG**  
**COMPOSITION**

GRANADA grigio terra: 50%  
 SANTIAGO grigio terra: 20%  
 ARENAL crema: 10%  
 SASSO DI FIUME cenere: 10%  
 ANTICO MATTONE rosato: 10%



GRIGIO CHIARO

**COMPOSIZIONE**  
**COMPOSITION**  
**MISHUNG**  
**COMPOSITION**

ARENAL grigio chiaro: 45%  
 ARENAL terra: 5%  
 SANTIAGO grigio terra: 10%  
 TEIDE grigio chiaro: 20%  
 SASSO DI FIUME cenere: 10%  
 ANTICO MATTONE rosato: 10%



CREMA

**COMPOSIZIONE**  
**COMPOSITION**  
**MISHUNG**  
**COMPOSITION**

GRANADA crema: 60%  
 GRANADA grigio chiaro: 10%  
 SANTIAGO grigio terra: 10%  
 TEIDE bianco: 5%  
 SASSO DI FIUME cenere: 5%  
 ANTICO MATTONE rosato: 10%



GRIGIO ANTICO

**COMPOSIZIONE**  
**COMPOSITION**  
**MISHUNG**  
**COMPOSITION**

ARENAL grigio antico: 60%  
 ARENAL grigio chiaro: 20%  
 SASSO DI FIUME cenere: 10%  
 ANTICO MATTONE rosato: 10%

**SPECIFICHE DI PRODOTTO - PRODUCT SPECIFICATIONS - ANGABEN ZUM PRODUKT - CARACTÉRISTIQUES DU PRODUIT**

	DIMENSIONI DIMENSIONS ABMESSUNGEN DIMENSIONS	ALTEZZA HEIGHT HÖHE HAUTEUR	LUNGHEZZA LENGHT LÄNGE LONGUEUR	PESO A CONFEZIONE WEIGHT PER BOX GEWICHT/PACKUNG POIDS PAR BOÎTE	CONFEZIONE* PACKAGING PACKUNG BOÎTE	SPESSORE THICKNESS DICKE ÉPAISSEUR	POSA INSTALLATION VERLEGUNG POSE
<b>ELEMENTI PIANI</b> <b>FLAT ELEMENTS</b> <b>FLACHE ELEMENTE</b> <b>ÉLÉMENTS PLATS</b>	da 30,00 cm <sup>2</sup> a 1225,00 cm	-	-	≅ 39,00 kg	1,00 m <sup>2</sup> (25,00 m <sup>2</sup> /pallet)	2,00 - 5,00 cm	fugato gouté mit Fuge avec joint
<b>ELEMENTI ANGOLARI</b> <b>CORNER ELEMENTS</b> <b>ECKELEMENTE</b> <b>ÉLÉMENTS D'ANGLE</b>	-	da 5,50 cm a 36,00 cm	da 8,00 cm a 28,00 cm	≅ 26,00 kg	2,00 m (60,00 m/pallet)	2,00 - 5,00 cm	

**RESA - YIELD - VERBRAUCH - RENDEMENT: ARREDOCOLLA 6-7 kg/m<sup>2</sup> / ARREDOSTUCCO 8-10 kg/m<sup>2</sup>**

\*Giunto compreso | Joint included | einschließlich Fuge | joint compris ± 5%





# “Borgonovo

*Un amalgama di colori, rilievi e forme plasmate dalle abili mani degli scalpellini che si muovono al ritmo del tempo, guidati da un sapere ancestrale che affonda le sue radici negli antichi borghi del centro Italia. Borgonovo porta con sé gli echi di comunità protette tra alte mura e anima le pareti di una vivacità perduta.*

*An amalgam of colours, reliefs and shapes moulded by the skilled hands of stonecutters moving to the rhythm of time, guided by an ancestral knowledge that has its own roots in the ancient villages of central Italy. Borgonovo contains the echoes of communities protected by high walls and animates such walls with a lost vivacity.*

*Eine Mischung aus Farben, Reliefs und Formen, geformt von den geschickten Händen der Steinmetze, die sich im Rhythmus der Zeit bewegen, geleitet von einem überlieferten Wissen, das seine Wurzeln in den alten Dörfern Mittelitaliens hat. Borgonovo trägt das Echo von Gemeinden in sich, die durch hohe Mauern geschützt sind, belebt die Mauern mit einer verlorengeglaufter Lebendigkeit.*

*Un amalgame de couleurs, de reliefs et de formes façonnés par les mains habiles des tailleurs de pierre qui évoluent au rythme du temps, guidés par un savoir-faire ancestral qui puise ses racines dans les anciens villages de l'Italie centrale. Borgonovo apporte avec lui les échos des communautés protégées entre de hauts murs et anime les murs d'une vivacité perdue.*

# Borgonovo



BORGONOVO

**COMPOSIZIONE**  
**COMPOSITION**  
**MISHUNG**  
**COMPOSITION**

ARENAL grigio chiaro: 40%

ARENAL terra: 10%

ARENAL grigio terra: 20%

ARENAL marrone scuro: 10%

OLKARIA terra: 10%

ANTICO MATTONE rosato: 10%

**SPECIFICHE DI PRODOTTO - PRODUCT SPECIFICATIONS - ANGABEN ZUM PRODUKT - CARACTÉRISTIQUES DU PRODUIT**

	DIMENSIONI DIMENSIONS ABMESSUNGEN DIMENSIONS	ALTEZZA HEIGHT HÖHE HAUTEUR	LUNGHEZZA LENGTH LÄNGE LONGUEUR	PESO A CONFEZIONE WEIGHT PER BOX GEWICHT/PACKUNG POIDS PAR BOÎTE	CONFEZIONE* PACKAGING PACKUNG BOÎTE	SPESSORE THICKNESS DICKE ÉPAISSEUR	POSA INSTALLATION VERLEGUNG POSE
<b>ELEMENTI PIANI</b> <b>FLAT ELEMENTS</b> <b>FLACHE ELEMENTE</b> <b>ÉLÉMENTS PLATS</b>	da 30,00 cm <sup>2</sup> a 1225,00 cm	-	-	≈ 35,00 kg	1,00 m <sup>2</sup> (25,00 m <sup>2</sup> /pallet)	2,00 - 5,00 cm	fugato grouted mit Fuge avec joint
<b>ELEMENTI ANGOLARI</b> <b>CORNER ELEMENTS</b> <b>ECKELEMENTE</b> <b>ÉLÉMENTS D'ANGLE</b>	-	da 5,50 cm a 36,00 cm	da 8,00 cm a 28,00 cm	≈ 26,00 kg	2,00 m (60,00 m/pallet)	2,00 - 5,00 cm	

**RESA - YIELD - VERBRAUCH - RENDEMENT: ARREDOCOLLA 6-7 kg/m<sup>2</sup> / ARREDOSTUCCO 8-10 kg/m<sup>2</sup>**

\*Giunto compreso | Joint included | einschließlich Fuge | joint compris ± 5%















# “Cortevecchio

*Ispirata alle pietre dalle superfici frastagliate delle fortezze medievali, Cortevecchio imprime alle pareti un fascino arcano e richiama alla mente l'immagine di antiche battaglie. Una pietra carica di emozioni che conferisce un'aura epica al design delle costruzioni che la utilizzano.*

*Inspired by the stones from the jagged surfaces of medieval fortresses, Cortevecchio gives the walls an arcane charm and evokes the image of ancient battles. A stone that is full of emotions and gives an epic aura to the design of any buildings using it.*

*Inspiziert von den zerklüfteten Steinoberflächen mittelalterlicher Festungen, verleiht Cortevecchio den Mauern einen geheimnisvollen Charme und beschwört Bilder von alten Schlachten herauf. Ein Stein voller Emotionen, der dem Design der Gebäude, in denen er verwendet wird, eine epische Aura verleiht.*

*Inspirée par les pierres aux surfaces irrégulières des forteresses médiévales, Cortevecchio donne aux murs un charme mystérieux et rappelle l'image des batailles antiques. Une pierre chargée d'émotions qui donne une aura épique au design des bâtiments qui l'utilisent.*

# Cortevecchio



CORTEVECCHIO

## COMPOSIZIONE COMPOSITION MISHUNG COMPOSITION

ARENAL grigio terra: 35%

ARENAL terra: 20%

SANTIAGO grigio chiaro: 20%

SANTIAGO marrone scuro: 5%

TEIDE grigio chiaro: 20%

### SPECIFICHE DI PRODOTTO - PRODUCT SPECIFICATIONS - ANGABEN ZUM PRODUKT - CARACTÉRISTIQUES DU PRODUIT

	DIMENSIONI DIMENSIONS ABMESSUNGEN DIMENSIONS	ALTEZZA HEIGHT HÖHE HAUTEUR	LUNGHEZZA LENGHT LÄNGE LONGUEUR	PESO A CONFEZIONE WEIGHT PER BOX GEWICHT/PACKUNG POIDS PAR BOÎTE	CONFEZIONE* PACKAGING PACKUNG BOÎTE	SPESSORE THICKNESS DICKE ÉPAISSEUR	POSA INSTALLATION VERLEGUNG POSE
<b>ELEMENTI PIANI</b> <b>FLAT ELEMENTS</b> <b>FLACHE ELEMENTE</b> <b>ÉLÉMENTS PLATS</b>	da 30,00 cm <sup>2</sup> a 1225,00 cm	-	-	≅ 33,00 kg	1,00 m <sup>2</sup> (25,00 m <sup>2</sup> /pallet)	2,00 - 5,00 cm	fugato grouted mit Fuge avec joint
<b>ELEMENTI ANGOLARI</b> <b>CORNER ELEMENTS</b> <b>ECKELEMENTE</b> <b>ÉLÉMENTS D'ANGLE</b>	-	da 5,50 cm a 36,00 cm	da 8,00 cm a 28,00 cm	≅ 24,00 kg	2,00 m (60,00 m/pallet)	2,00 - 5,00 cm	

RESA - YIELD - VERBRAUCH - RENDEMENT: ARREDOCOLLA 6-7 kg/m<sup>2</sup> / ARREDOSTUCCO 8-10 kg/m<sup>2</sup>

\*Giunto compreso | Joint included | einschließlich Fuge | joint compris ± 5%







# “Cortona

*Ispirato all'edilizia rurale della città da cui prende il nome, Cortona, nel cuore della campagna toscana, questo rivestimento combina l'antico mattone in terracotta con le forme irregolari della pietra locale. Il colore rossiccio del mattone si amalgama con le sfumature della pietra, che vanno dal crema all'ocra, al grigio, creando un effetto cromatico che richiama la terra coltivata.*

*Inspired by the rural buildings of Cortona, the town from which it takes its name, located in the heart of Tuscan countryside, this cladding combines the ancient terracotta brick with the irregular shapes of local stone. The reddish colour of brick blends with the shades of stone, ranging from cream to ochre to grey, thus creating a chromatic effect recalling cultivated lands.*

*Inspiriert von den ländlichen Gebäuden der namensgebenden Stadt, Cortona im Herzen der Toskana, kombiniert diese Verkleidung alte Terrakotta-Ziegel mit den unregelmäßigen Formen des örtlichen Steins. Die rötliche Farbe des Ziegels vermischt sich mit den Schattierungen des Steins, die von cremefarben über ockerfarben bis hin zu dunkelgrau reichen, so dass ein Farbeffekt entsteht, der an Ackerland erinnert.*

*Inspiré par la construction rurale de Cortona, la ville dont il tire son nom, au cœur de la campagne toscane, ce revêtement associe la brique de terre cuite ancienne aux formes irrégulières de la pierre locale. La couleur rougeâtre de la brique se mêle aux nuances de la pierre, allant du crème à l'ocre en passant par le gris foncé, créant un effet chromatique qui rappelle la terre cultivée.*

# Cortona



CORTONA

## COMPOSIZIONE COMPOSITION MISHUNG COMPOSITION

ARENAL sabbia: 30%

TEIDE grigio chiaro: 45%

TEIDE grigio terra: 20%

ANTICO MATTONE arancio: 2%

ANTICO MATTONE rosato: 3%

### SPECIFICHE DI PRODOTTO - PRODUCT SPECIFICATIONS - ANGABEN ZUM PRODUKT - CARACTÉRISTIQUES DU PRODUIT

	DIMENSIONI DIMENSIONS ABMESSUNGEN DIMENSIONS	ALTEZZA HEIGHT HÖHE HAUTEUR	LUNGHEZZA LENGTH LÄNGE LONGUEUR	PESO A CONFEZIONE WEIGHT PER BOX GEWICHT/PACKUNG POIDS PAR BOÎTE	CONFEZIONE* PACKAGING PACKUNG BOÎTE	SPESSORE THICKNESS DICKE ÉPAISSEUR	POSA INSTALLATION VERLEGUNG POSE
<b>ELEMENTI PIANI</b> <b>FLAT ELEMENTS</b> <b>FLACHE ELEMENTE</b> <b>ÉLÉMENTS PLATS</b>	da 30,00 cm <sup>2</sup> a 1225,00 cm	-	-	≅ 34,00 kg	1,00 m <sup>2</sup> (25,00 m <sup>2</sup> /pallet)	2,00 - 5,00 cm	fugato grouted mit Fuge avec joint
<b>ELEMENTI ANGOLARI</b> <b>CORNER ELEMENTS</b> <b>ECKELEMENTE</b> <b>ÉLÉMENTS D'ANGLE</b>	-	da 5,50 cm a 36,00 cm	da 8,00 cm a 28,00 cm	≅ 24,00 kg	2,00 m (60,00 m/pallet)	2,00 - 5,00 cm	

RESA - YIELD - VERBRAUCH - RENDEMENT: ARREDOCOLLA 6-7 kg/m<sup>2</sup> / ARREDOSTUCCO 8-10 kg/m<sup>2</sup>

\*Giunto compreso | Joint included | einschließlich Fuge | joint compris ± 5%











# “Toscano

*Arenaria, mattone e sasso di fiume si mescolano per creare un rivestimento ispirato ai casolari delle campagne toscane, adagiati sulle colline del Chianti, tra i filari ordinati dei vigneti. Toscano è un omaggio al paesaggio rurale più iconico d'Italia, dove i cipressi seguono le curve dolci delle strade che attraversano i poderi e il sole al tramonto sembra baciare il profilo dei colli.*

*Sandstone, brick and river stone mixing up to create a cladding inspired by the farmhouses of Tuscan countryside, standing on the hills of Chianti, among the neat rows of vineyards. Toscano is a tribute to the most iconic rural landscape in Italy, where cypresses follow the gentle curves of the roads crossing the farms and the setting sun seems to kiss the profile of hills.*

*Sandstein, Ziegelstein und Flussgestein wurden zu einer Verkleidung gemischt, die von den Häusern der toskanischen Landschaft inspiriert ist, die sich zwischen den akkuraten Reihen der Weinberge an die Hügel des Chianti schmiegen. Toscano ist eine Hommage an Italiens berühmteste ländliche Gegend, wo die Zypressen den sanften Kurven der Straßen durch die Gehöfte folgen und die untergehende Sonne das Profil der Hügel zu küssen scheint.*

*Le grès, la brique et la pierre de rivière se mélangent pour créer un revêtement inspiré des fermes de la campagne toscane, situées dans les collines du Chianti, parmi les rangées ordonnées de vignes. Toscano est un hommage au paysage rural le plus emblématique d'Italie, où les cyprès suivent les courbes douces des routes qui traversent les fermes, et où le soleil couchant semble embrasser le profil des collines.*

# Toscano



TERRA

**COMPOSIZIONE**  
**COMPOSITION**  
**MISHUNG**  
**COMPOSITION**

ARENAL terra: 50%

ARENAL sabbia: 20%

ARENAL marrone scuro: 15%

ANTICO MATTONE rosato: 10%

SASSO DI FIUME cenere: 5%

**SPECIFICHE DI PRODOTTO - PRODUCT SPECIFICATIONS - ANGABEN ZUM PRODUKT - CARACTÉRISTIQUES DU PRODUIT**

	DIMENSIONI DIMENSIONS ABMESSUNGEN DIMENSIONS	ALTEZZA HEIGHT HÖHE HAUTEUR	LUNGHEZZA LENGHT LÄNGE LONGUEUR	PESO A CONFEZIONE WEIGHT PER BOX GEWICHT/PACKUNG POIDS PAR BOÎTE	CONFEZIONE* PACKAGING PACKUNG BOÎTE	SPESSORE THICKNESS DICKE ÉPAISSEUR	POSA INSTALLATION VERLEGUNG POSE
<b>ELEMENTI PIANI</b> <b>FLAT ELEMENTS</b> <b>FLACHE ELEMENTE</b> <b>ÉLÉMENTS PLATS</b>	da 30,00 cm <sup>2</sup> a 1225,00 cm	-	-	≈ 34,00 kg	1,00 m <sup>2</sup> (25,00 m <sup>2</sup> /pallet)	2,00 - 5,00 cm	fugato grouted mit Fuge avec joint
<b>ELEMENTI ANGOLARI</b> <b>CORNER ELEMENTS</b> <b>ECKELEMENTE</b> <b>ÉLÉMENTS D'ANGLE</b>	-	da 5,50 cm a 34,00 cm	da 3,00 cm a 28,00 cm	≈ 24,00 kg	2,00 m (60,00 m/pallet)	2,00 - 5,00 cm	

**RESA - YIELD - VERBRAUCH - RENDEMENT: ARREDOCOLLA 6-7 kg/m<sup>2</sup> / ARREDOSTUCCO 8-10 kg/m<sup>2</sup>**

\*Giunto compreso | Joint included | einschließlich Fuge | joint compris ± 5%











# “Etrusco

*Un amalgama di colori e forme: le linee dritte del mattone intersecano quelle irregolari dell'arenaria e quelle tondeggianti del sasso di fiume creando un insieme armonioso che si integra con la natura circostante. Etrusco è un omaggio alle origini italiche e alle civiltà che, era dopo era, hanno scritto la loro storia nella pietra.*

*An amalgam of colours and shapes: the straight lines of brick intersect the irregular lines of sandstone and the rounded lines of river stone, thus creating a harmonious whole that becomes part of the surrounding nature. Etrusco is a tribute to the Italic origins and to the civilisations who wrote their history in stone, era after era.*

*Eine Verschmelzung aus Farben und Formen: Die geraden Linien des Ziegels überschneiden sich mit den unregelmäßigen Linien des Sandsteins und den abgerundeten Linien des Flussgesteins und bilden ein harmonisches Ganzes, das sich in die umgebende Natur einfügt. Etrusco ist eine Hommage an die italischen Ursprünge und Zivilisationen, die Epoche für Epoche ihre Geschichte in Stein geschrieben haben.*

*Un amalgame de couleurs et de formes: les lignes droites de la brique croisent celles irrégulières du grès et celles arrondies de la pierre de rivière, créant un ensemble harmonieux qui s'intègre à la nature environnante. Etrusco est un hommage aux origines italiques et aux civilisations qui, époque après époque, ont gravé leur histoire dans la pierre.*

# Etrusco



TERRA

## COMPOSIZIONE COMPOSITION MISHUNG COMPOSITION

ARENAL terra: 40%  
ARENAL grigio terra: 10%  
ARENAL marrone scuro: 10%  
TEIDE terra: 30%  
SASSO DI FIUME cenere: 3%  
ANTICO MATTONE rosso: 2%  
ANTICO MATTONE rosato: 5%

### SPECIFICHE DI PRODOTTO - PRODUCT SPECIFICATIONS - ANGABEN ZUM PRODUKT - CARACTÉRISTIQUES DU PRODUIT

	DIMENSIONI DIMENSIONS ABMESSUNGEN DIMENSIONS	ALTEZZA HEIGHT HÖHE HAUTEUR	LUNGHEZZA LENGHT LÄNGE LONGUEUR	PESO A CONFEZIONE WEIGHT PER BOX GEWICHT/PACKUNG POIDS PAR BOÎTE	CONFEZIONE* PACKAGING PACKUNG BOÎTE	SPESSORE THICKNESS DICKE ÉPAISSEUR	POSA INSTALLATION VERLEGUNG POSE
<b>ELEMENTI PIANI</b> <b>FLAT ELEMENTS</b> <b>FLACHE ELEMENTE</b> <b>ÉLÉMENTS PLATS</b>	da 30,00 cm <sup>2</sup> a 1225,00 cm	-	-	≅ 35,00 kg	1,00 m <sup>2</sup> (25,00 m <sup>2</sup> /pallet)	2,00 - 5,00 cm	fugato grouted mit Fuge avec joint
<b>ELEMENTI ANGOLARI</b> <b>CORNER ELEMENTS</b> <b>ECKELEMENTE</b> <b>ÉLÉMENTS D'ANGLE</b>	-	da 5,50 cm a 34,00 cm	da 3,00 cm a 28,00 cm	≅ 26,00 kg	2,00 m (60,00 m/pallet)	2,00 - 5,00 cm	

RESA - YIELD - VERBRAUCH - RENDEMENT: ARREDOCOLLA 6-7 kg/m<sup>2</sup> / ARREDOSTUCCO 8-10 kg/m<sup>2</sup>

\*Giunto compreso | Joint included | einschließlich Fuge | joint compris ± 5%











# “Alpino

*Pietre miste dalle forme irregolari ispirate ai profili rocciosi delle Alpi, confine naturale d'Italia. Utilizzato sulle pareti esterne, Alpino evoca paesaggi d'alta quota dove le creste impervie fanno da contorno a prati e pascoli e le finestre delle case si affacciano su specchi d'acqua limpidissima che riflettono le cime innevate.*

*Mixed stones with irregular shapes inspired by the rocky profiles of the Alps, the natural border of Italy. Used on external walls, Alpino evokes high-altitude landscapes where rugged ridges surround meadows and pastures and where the windows of houses overlook mirrors of crystal clear water which reflect snow-capped peaks.*

*Unterschiedliche Steine mit unregelmäßigen Formen, inspiriert von den felsigen Profilen der Alpen, der natürlichen Grenze Italiens. Bei der Verwendung an Außenwänden erinnert Alpino an hochgelegene Landschaften, in denen undurchdringliche Bergrücken von Wiesen und Weiden umgeben sind und die Fenster der Häuser auf glasklares Wasser blicken, in dem sich die schneebedeckten Gipfel spiegeln.*

*Pierres mélangées aux formes irrégulières inspirées des profils rocheux des Alpes, frontière naturelle de l'Italie. Utilisé sur les murs extérieurs, Alpino évoque des paysages de haute altitude où les crêtes accidentées entourent les prairies et les pâturages, et où les fenêtres des maisons donnent sur l'eau cristalline reflétant les sommets enneigés.*

# Alpino



GRIGIO CHIARO



TERRA

**COMPOSIZIONE  
COMPOSITION  
MISHUNG  
COMPOSITION**

TEIDE grigio chiaro: 60%  
ARENAL grigio chiaro: 20%  
SANTIAGO grigio chiaro: 20%

**COMPOSIZIONE  
COMPOSITION  
MISHUNG  
COMPOSITION**

MADERA grigio chiaro: 25%  
TEIDE terra: 25%  
SANTIAGO marrone scuro: 15%  
SANTIAGO grigio chiaro: 15%  
ARENAL terra: 10%  
LOKON marrone chiaro: 10%

**SPECIFICHE DI PRODOTTO - PRODUCT SPECIFICATIONS - ANGABEN ZUM PRODUKT - CARACTÉRISTIQUES DU PRODUIT**

	DIMENSIONI DIMENSIONS ABMESSUNGEN DIMENSIONS	ALTEZZA HEIGHT HÖHE HAUTEUR	LUNGHEZZA LENGHT LÄNGE LONGUEUR	PESO A CONFEZIONE WEIGHT PER BOX GEWICHT/PACKUNG POIDS PAR BOÎTE	CONFEZIONE* PACKAGING PACKUNG BOÎTE	SPESSORE THICKNESS DICKE ÉPAISSEUR	POSA INSTALLATION VERLEGUNG POSE
<b>ELEMENTI PIANI FLAT ELEMENTS FLACHE ELEMENTE ÉLÉMENTS PLATS</b>	da 30,00 cm <sup>2</sup> a 1225,00 cm	-	-	≈ 40,00 kg	1,00 m <sup>2</sup> (25,00 m <sup>2</sup> /pallet)	2,00 - 6,50 cm	fugato grouted mit Fuge avec joint
<b>ELEMENTI ANGOLARI CORNER ELEMENTS ECKELEMENTE ÉLÉMENTS D'ANGLE</b>	-	da 5,00 cm a 36,00 cm	da 8,00 cm a 28,00 cm	≈ 30,00 kg	2,00 m (60,00 m/pallet)	2,00 - 6,50 cm	

**RESA - YIELD - VERBRAUCH - RENDEMENT: ARREDOCOLLA 6-7 kg/m<sup>2</sup> / ARREDOSTUCCO 8-10 kg/m<sup>2</sup>**

\*Giunto compreso | Joint included | einschließlich Fuge | joint compris ± 5%











# “Montano

*Una composizione di elementi squadrati dall'estetica solida e compatta, proposta sia in tonalità calde, con sfumature di marrone, sia in una versione più fredda, che gioca con i toni di grigio. Utilizzato in interni Montano crea un ambiente intimo e accogliente, mentre in esterni conferisce agli edifici una caratterizzazione fortemente nordica.*

*A composition of square elements with solid and compact aesthetic, proposed in warm shades, with nuances of brown, and in a cooler-coloured version, playing with shades of grey. When used indoors, Montano creates an intimate and welcoming environment, while outdoors it gives the buildings a Nordic character.*

*Eine Komposition aus quadratischen Elementen mit einer soliden und kompakten Ästhetik, die sowohl in warmen Farben mit Brauntönen als auch in einer kühleren Version, die mit Grautönen spielt, angeboten wird. Im Innenbereich schafft Montano ein intimes und gemütliches Ambiente, während er im Außenbereich Gebäuden einen nordischen Charakter verleiht.*

*Une composition d'éléments carrés à l'esthétique solide et compacte, proposée à la fois dans des tons chauds, avec des nuances de marron, et dans une version plus froide, qui joue avec les tons de gris. Utilisé à l'intérieur, Montano crée un environnement intime et accueillant, tandis qu'à l'extérieur, il donne aux bâtiments un caractère nordique.*

# Montano



GRIGIO TERRA



GRIGIO CHIARO

**COMPOSIZIONE  
COMPOSITION  
MISHUNG  
COMPOSITION**

SANTIAGO grigio terra: 40%  
SANTIAGO grigio chiaro: 10%  
ARENAL grigio terra: 20%  
ARENAL grigio antico: 10%  
TEIDE grigio terra: 20%

**COMPOSIZIONE  
COMPOSITION  
MISHUNG  
COMPOSITION**

SANTIAGO grigio chiaro: 40%  
SANTIAGO grigio terra: 10%  
TEIDE grigio: 20%  
TEIDE grigio chiaro: 20%  
ARENAL marrone scuro: 10%

**SPECIFICHE DI PRODOTTO - PRODUCT SPECIFICATIONS - ANGABEN ZUM PRODUKT - CARACTÉRISTIQUES DU PRODUIT**

	DIMENSIONI DIMENSIONS ABMESSUNGEN DIMENSIONS	ALTEZZA HEIGHT HÖHE HAUTEUR	LUNGHEZZA LENGHT LÄNGE LONGUEUR	PESO A CONFEZIONE WEIGHT PER BOX GEWICHT/PACKUNG POIDS PAR BOÎTE	CONFEZIONE* PACKAGING PACKUNG BOÎTE	SPESSORE THICKNESS DICKE ÉPAISSEUR	POSA INSTALLATION VERLEGUNG POSE
<b>ELEMENTI PIANI FLAT ELEMENTS FLACHE ELEMENTE ÉLÉMENTS PLATS</b>	da 30,00 cm <sup>2</sup> a 1225,00 cm	-	-	≈ 41,00 kg	1,00 m <sup>2</sup> (25,00 m <sup>2</sup> /pallet)	2,00 - 5,00 cm	fugato grouted mit Fuge avec joint
<b>ELEMENTI ANGOLARI CORNER ELEMENTS ECKELEMENTE ÉLÉMENTS D'ANGLE</b>	-	da 8,00 cm a 36,00 cm	da 8,00 cm a 28,00 cm	≈ 30,00 kg	2,00 m (60,00 m/pallet)	2,00 - 5,00 cm	

**RESA - YIELD - VERBRAUCH - RENDEMENT: ARREDOCOLLA 6-7 kg/m<sup>2</sup> / ARREDOSTUCCO 8-10 kg/m<sup>2</sup>**

\*Giunto compreso | Joint included | einschließlich Fuge | joint compris ± 5%











# ‘‘Tirolese

*L'alternarsi di forme irregolari crea un labirinto di linee tra le superfici increspate degli elementi che compongono questo rivestimento, disponibile sia in color terra che nelle tonalità del grigio. Tirolese evoca i paesaggi incontaminati della regione da cui prende il nome, dove la geografia naturale lega insieme popoli e culture.*

*The alternation of irregular shapes creates a maze of lines among the rippled surfaces of the elements composing this cladding, available in earth tones and nuances of grey as well. Tirolese evokes the uncontaminated landscapes of the region from which it takes its name, where natural geography binds peoples and cultures together.*

*Der Wechsel von unregelmäßigen Formen schafft ein Labyrinth von Linien zwischen den gewellten Oberflächen der Elemente, aus denen diese Wandverkleidung besteht, die sowohl in Erd- als auch in Grautönen erhältlich ist. Tirolese erinnert an die unberührten Landschaften der namensgebenden Region, wo die natürliche Geografie Völker und Kulturen miteinander.*

*L'alternance de formes irrégulières crée un labyrinthe de lignes entre les surfaces ondulées des éléments qui composent ce revêtement, disponible dans les tons de terre et les nuances de gris. Tirolese évoque les paysages intacts de la région dont il tire son nom, où la géographie naturelle lie les peuples et les cultures.*

# Tirolese



GRIGIO ANTICO

**COMPOSIZIONE**  
**COMPOSITION**  
**MISHUNG**  
**COMPOSITION**

TEIDE grigio chiaro: 60%  
SANTIAGO grigio antico: 40%



TERRA

**COMPOSIZIONE**  
**COMPOSITION**  
**MISHUNG**  
**COMPOSITION**

TEIDE grigio terra: 40%  
TEIDE terra: 30%  
MADERA terra: 30%



GRIGIO

**COMPOSIZIONE**  
**COMPOSITION**  
**MISHUNG**  
**COMPOSITION**

TEIDE grigio chiaro: 40%  
TEIDE grigio: 30%  
MADERA grigio chiaro: 30%

## SPECIFICHE DI PRODOTTO - PRODUCT SPECIFICATIONS - ANGABEN ZUM PRODUKT - CARACTÉRISTIQUES DU PRODUIT

	DIMENSIONI DIMENSIONS ABMESSUNGEN DIMENSIONS	ALTEZZA HEIGHT HÖHE HAUTEUR	LUNGHEZZA LENGTH LÄNGE LONGUEUR	PESO A CONFEZIONE WEIGHT PER BOX GEWICHT/PACKUNG POIDS PAR BOÎTE	CONFEZIONE* PACKAGING PACKUNG BOÎTE	SPESSORE THICKNESS DICKE ÉPAISSEUR	POSA INSTALLATION VERLEGUNG POSE
<b>ELEMENTI PIANI</b> <b>FLAT ELEMENTS</b> <b>FLACHE ELEMENTE</b> <b>ÉLÉMENTS PLATS</b>	da 30,00 cm <sup>2</sup> a 1200,00 cm	-	-	≈ 40,00 kg	1,00 m <sup>2</sup> (25,00 m <sup>2</sup> /pallet)	2,50 - 5,00 cm	fugato grouted mit Fuge avec joint
<b>ELEMENTI ANGOLARI</b> <b>CORNER ELEMENTS</b> <b>ECKELEMENTE</b> <b>ÉLÉMENTS D'ANGLE</b>	-	da 14,00 cm a 36,00 cm	da 5,00 cm a 25,00 cm	≈ 30,00 kg	2,00 m (60,00 m/pallet)	2,50 - 5,00 cm	

RESA - YIELD - VERBRAUCH - RENDEMENT: ARREDOCOLLA 6-7 kg/m<sup>2</sup> / ARREDOSTUCCO 8-10 kg/m<sup>2</sup>

\*Giunto compreso | Joint included | einschließlich Fuge | joint compris ± 5%







# “Dolomite

*Forme aguzze si alternano a superfici più ampie, ma sempre scagliate, arricchite di rilievi e depressioni che, illuminate dal sole, creano suggestivi giochi di luce, proprio come quelli che rendono uniche le Dolomiti, le montagne piene di conchiglie e fossili marini, ricordo di un'era lontana.*

*Sharp shapes alternate with larger surfaces, always jagged, enriched with reliefs and depressions which, as lit by the sun, create involving plays of light, just like those making the Dolomites unique, mountains full of shells and marine fossils, a memory of an era so far away.*

*Kantige Formen wechseln sich mit breiteren Flächen ab, die aber immer bearbeitet sind, angereichert mit Reliefs und Vertiefungen, die bei Sonneneinstrahlung suggestive Lichtspiele erzeugen, so wie die, die die Dolomiten einzigartig machen, die Berge voller Muscheln und Meeresfossilien, Erinnerungen an eine längst vergangene Zeit.*

*Des formes pointues alternent avec des surfaces plus grandes, mais toujours écaillées, enrichies de reliefs et de dépressions qui, illuminées par le soleil, créent des jeux de lumière suggestifs, tout comme ceux qui rendent les Dolomites uniques, les montagnes pleines de coquillages et de fossiles marins, un souvenir d'une époque lointaine.*

# Dolomite



MARRONE CHIARO



GRIGIO CHIARO

**COMPOSIZIONE**  
**COMPOSITION**  
**MISHUNG**  
**COMPOSITION**

SANTIAGO grigio terra: 40%  
LOKON marrone chiaro: 30%  
MADERA terra: 30%

**COMPOSIZIONE**  
**COMPOSITION**  
**MISHUNG**  
**COMPOSITION**

SANTIAGO grigio: 40%  
LOKON grigio chiaro: 30%  
MADERA grigio chiaro: 30%

**SPECIFICHE DI PRODOTTO - PRODUCT SPECIFICATIONS - ANGABEN ZUM PRODUKT - CARACTÉRISTIQUES DU PRODUIT**

	DIMENSIONI DIMENSIONS ABMESSUNGEN DIMENSIONS	ALTEZZA HEIGHT HÖHE HAUTEUR	LUNGHEZZA LENGHT LÄNGE LONGUEUR	PESO A CONFEZIONE WEIGHT PER BOX GEWICHT/PACKUNG POIDS PAR BOÎTE	CONFEZIONE* PACKAGING PACKUNG BOÎTE	SPESSORE THICKNESS DICKE ÉPAISSEUR	POSA INSTALLATION VERLEGUNG POSE
<b>ELEMENTI PIANI</b> <b>FLAT ELEMENTS</b> <b>FLACHE ELEMENTE</b> <b>ÉLÉMENTS PLATS</b>	da 30,00 cm <sup>2</sup> a 1200,00 cm	-	-	≈ 40,00 kg	1,00 m <sup>2</sup> (25,00 m <sup>2</sup> /pallet)	2,00 - 6,50 cm	fugato grouted mit Fuge avec joint
<b>ELEMENTI ANGOLARI</b> <b>CORNER ELEMENTS</b> <b>ECKELEMENTE</b> <b>ÉLÉMENTS D'ANGLE</b>	-	da 5,00 cm a 35,00 cm	da 5,00 cm a 30,00 cm	≈ 30,00 kg	2,00 m (60,00 m/pallet)	2,00 - 6,50 cm	

**RESA - YIELD - VERBRAUCH - RENDEMENT: ARREDOCOLLA 6-7 kg/m<sup>2</sup> / ARREDOSTUCCO 10-12 kg/m<sup>2</sup>**

\*Giunto compreso | Joint included | einschließlich Fuge | joint compris ± 5%





# “Veneto

*Elementi quadrati dai colori chiari, che alternano superfici levigate e frastagliate, e creano sorprendenti suggestioni tattili e visive. Veneto è ispirata alla pietra dei Colli Euganei che si stagliano inaspettati nel mezzo della pianura: un omaggio a questo paesaggio che ha stregato l'immaginazione di innumerevoli artisti e artigiani.*

*Square elements in light colours, alternating smooth and jagged surfaces and creating surprising tactile and visual suggestions. Veneto is inspired by the stone of the Euganean Hills, which unexpectedly stand out in the middle of the plain: a tribute to this very peculiar landscape that has bewitched the imagination of countless artists and craftsmen.*

*Quadratische Elemente in hellen Farben, abwechselnd mit glatten und zerklüfteten Oberflächen, schaffen überraschende haptische und optische Eindrücke. Veneto ist inspiriert vom Stein der Euganeischen Hügel, die sich unerwartet mitten in der Ebene erheben: eine Hommage an diese ganz besondere Landschaft, die die Phantasie unzähliger Künstler und Handwerker beflügelt hat.*

*Des éléments carrés aux couleurs claires, qui alternent des surfaces lisses et irrégulières et créent des suggestions tactiles et visuelles surprenantes. Veneto s'inspire de la pierre des Monts Euganéens qui se détachent de manière inattendue au milieu de la plaine: un hommage à ce paysage très particulier qui a envoûté l'imagination d'innombrables artistes et artisans.*

# Veneto



CREMA

## COMPOSIZIONE COMPOSITION MISHUNG COMPOSITION

ARENAL crema: 60%  
ARENAL grigio terra: 5%  
TEIDE grigio terra 25%  
SANTIAGO grigio terra 10%

### SPECIFICHE DI PRODOTTO - PRODUCT SPECIFICATIONS - ANGABEN ZUM PRODUKT - CARACTÉRISTIQUES DU PRODUIT

	DIMENSIONI DIMENSIONS ABMESSUNGEN DIMENSIONS	ALTEZZA HEIGHT HÖHE HAUTEUR	LUNGHEZZA LENGTH LÄNGE LONGUEUR	PESO A CONFEZIONE WEIGHT PER BOX GEWICHT/PACKUNG POIDS PAR BOÎTE	CONFEZIONE* PACKAGING PACKUNG BOÎTE	SPESSORE THICKNESS DICKE ÉPAISSEUR	POSA INSTALLATION VERLEGUNG POSE
<b>ELEMENTI PIANI</b> <b>FLAT ELEMENTS</b> <b>FLACHE ELEMENTE</b> <b>ÉLÉMENTS PLATS</b>	da 20,00 cm <sup>2</sup> a 1225,00 cm	-	-	≈ 35,00 kg	1,00 m <sup>2</sup> (25,00 m <sup>2</sup> /pallet)	2,00 - 5,00 cm	fugato grouted mit Fuge avec joint
<b>ELEMENTI ANGOLARI</b> <b>CORNER ELEMENTS</b> <b>ECKELEMENTE</b> <b>ÉLÉMENTS D'ANGLE</b>	-	da 8,00 cm a 36,00 cm	da 8,00 cm a 28,00 cm	≈ 26,00 kg	2,00 m (60,00 m/pallet)	2,00 - 5,00 cm	

RESA - YIELD - VERBRAUCH - RENDEMENT: ARREDOCOLLA 6-7 kg/m<sup>2</sup> / ARREDOSTUCCO 8-10 kg/m<sup>2</sup>

\*Giunto compreso | Joint included | einschließlich Fuge | joint compris ± 5%











# “Canova

*Mattoni e pietre mescolati ad arte per comporre un'armonia visiva che richiama alla mente l'opera dei grandi maestri della scultura. Canova celebra il rapporto tra l'uomo e la pietra e rende omaggio all'arte di modellare a colpi di scalpello, di intuire le forme prima che appaiono, di vedere la vita in un blocco inerte e plasmarlo imprimendogli emozioni che pulsano in eterno.*

*Bricks and stones artfully mixed to compose a visual harmony evoking the work of the great masters of sculpture. Canova celebrates the relationship between man and stone and pays homage to the art of modelling with chisels, intuiting shapes before they actually appear, seeing life in an inert block and moulding it by impressing it with any emotions pulsing forever.*

*Ziegel und Steine, kunstvoll gemischt, um eine visuelle Harmonie zu schaffen, die an die Werke der großen Meister der Bildhauerei erinnert. Canova zelebriert die Beziehung zwischen Mensch und Stein und huldigt der Kunst des Modellierens mit dem Meißel, der Wahrnehmung von Formen, bevor sie erscheinen, des Gewährwerdens des Lebens in einem trägen Block und der Formung desselben durch das Einprägen von Emotionen, die für die Ewigkeit bestehen.*

*Des briques et des pierres savamment mélangées pour composer une harmonie visuelle qui rappelle le travail des grands maîtres de la sculpture. Canova célèbre la relation entre l'homme et la pierre et rend hommage à l'art de modeler à coups de burin, de percevoir les formes avant qu'elles n'apparaissent, de voir la vie dans un bloc inerte et de le façonner en l'imprimant d'émotions qui palpitent éternellement.*

# Canova



GRIGIO TERRA



GRIGIO CHIARO

**COMPOSIZIONE**  
**COMPOSITION**  
**MISHUNG**  
**COMPOSITION**

TEIDE grigio terra: 60%  
ARENAL grigio terra: 33%  
ANTICO MATTONE rosato: 7%

**COMPOSIZIONE**  
**COMPOSITION**  
**MISHUNG**  
**COMPOSITION**

TEIDE grigio chiaro: 60%  
ARENAL grigio chiaro: 33%  
ANTICO MATTONE rosato: 7%

## SPECIFICHE DI PRODOTTO - PRODUCT SPECIFICATIONS - ANGABEN ZUM PRODUKT - CARACTÉRISTIQUES DU PRODUIT

	DIMENSIONI DIMENSIONS ABMESSUNGEN DIMENSIONS	ALTEZZA HEIGHT HÖHE HAUTEUR	LUNGHEZZA LENGHT LÄNGE LONGUEUR	PESO A CONFEZIONE WEIGHT PER BOX GEWICHT/PACKUNG POIDS PAR BOÎTE	CONFEZIONE* PACKAGING PACKUNG BOÎTE	SPESSORE THICKNESS DICKE ÉPAISSEUR	POSA INSTALLATION VERLEGUNG POSE
<b>ELEMENTI PIANI</b> <b>FLAT ELEMENTS</b> <b>FLACHE ELEMENTE</b> <b>ÉLÉMENTS PLATS</b>	da 30,00 cm <sup>2</sup> a 1225,00 cm	-	-	≈ 37,00 kg	1,00 m <sup>2</sup> (25,00 m <sup>2</sup> /pallet)	2,50 - 5,00 cm	fugato grouted mit Fuge avec joint
<b>ELEMENTI ANGOLARI</b> <b>CORNER ELEMENTS</b> <b>ECKELEMENTE</b> <b>ÉLÉMENTS D'ANGLE</b>	-	da 5,50 cm a 36,00 cm	da 8,00 cm a 28,00 cm	≈ 30,00 kg	2,00 m (60,00 m/pallet)	2,50 - 5,00 cm	

**RESA - YIELD - VERBRAUCH - RENDEMENT: ARREDOCOLLA 6-7 kg/m<sup>2</sup> / ARREDOSTUCCO 8-10 kg/m<sup>2</sup>**

\*Giunto compreso | Joint included | einschließlich Fuge | joint compris ± 5%









# ‘‘Ligure

*Elementi sottili dalle forme nette e dalle superfici appuntite, ammorbidite dall'improvvisa comparsa di pietre più grandi, questa composizione si ispira alle geografie incredibili delle scogliere liguri dove l'opera architettonica dell'uomo si erge arroccata tra le Alpi e il mare di Ponente.*

*With subtle elements with clear-cut shapes and pointed surfaces, softened by the sudden appearance of larger stones, this composition is inspired by the incredible geographies of the Ligurian cliffs, where men's architectural work stands on between the Alps and the western sea.*

*Zarte Elemente mit ausgeprägten Formen und spitzen Oberflächen, die durch das plötzliche Auftauchen größerer Steine gemildert werden. Diese Komposition ist von der unglaublichen Geografie der ligurischen Klippen inspiriert, wo sich das architektonische Werk des Menschen zwischen den Alpen und dem westlichen Mittelmeer erhebt.*

*Éléments fins aux formes nettes et aux surfaces pointues, adoucies par l'apparition soudaine de pierres plus grosses, cette composition s'inspire des incroyables géographies des falaises liguriennes où se dresse l'œuvre architecturale de l'homme perchée entre les Alpes et la mer du Ponant.*

# Ligure



GRIGIO CHIARO



BLU ANTICO

**COMPOSIZIONE**  
**COMPOSITION**  
**MISHUNG**  
**COMPOSITION**

ARENAL grigio antico: 10%  
LOKON grigio terra: 30%  
TEIDE grigio chiaro: 40%  
OLKARIA grigio antico: 20%

**COMPOSIZIONE**  
**COMPOSITION**  
**MISHUNG**  
**COMPOSITION**

SANTIAGO blu antico: 60%  
OLKARIA blu antico: 20%  
TEIDE grigio terra: 20%

## SPECIFICHE DI PRODOTTO - PRODUCT SPECIFICATIONS - ANGABEN ZUM PRODUKT - CARACTÉRISTIQUES DU PRODUIT

	DIMENSIONI DIMENSIONS ABMESSUNGEN DIMENSIONS	ALTEZZA HEIGHT HÖHE HAUTEUR	LUNGHEZZA LENGHT LÄNGE LONGUEUR	PESO A CONFEZIONE WEIGHT PER BOX GEWICHT/PACKUNG POIDS PAR BOÎTE	CONFEZIONE* PACKAGING PACKUNG BOÎTE	SPESSORE THICKNESS DICKE ÉPAISSEUR	POSA INSTALLATION VERLEGUNG POSE
<b>ELEMENTI PIANI</b> <b>FLAT ELEMENTS</b> <b>FLACHE ELEMENTE</b> <b>ÉLÉMENTS PLATS</b>	da 20,00 cm <sup>2</sup> a 1200,00 cm <sup>2</sup>	-	-	≈ 35,00 kg	1,00 m <sup>2</sup> (25,00 m <sup>2</sup> /pallet)	2,50 - 6,00 cm	fugato / a secco grouted / dry stacked mit Fuge / trocken avec joint / joint sec
<b>ELEMENTI ANGOLARI</b> <b>CORNER ELEMENTS</b> <b>ECKELEMENTE</b> <b>ÉLÉMENTS D'ANGLE</b>	-	da 7,00 cm a 36,00 cm	da 8,00 cm a 25,00 cm	≈ 26,00 kg	2,00 m (60,00 m/pallet)	2,50 - 6,00 cm	

**RESA - YIELD - VERBRAUCH - RENDEMENT: ARREDOCOLLA 6-7 kg/m<sup>2</sup> / ARREDOSTUCCO 8-10 kg/m<sup>2</sup>**

Per posa a secco prevedere nell'ordine un quantitativo di pietra maggiora di ≈ 15% | For dry stacked installation, the quantity of sane ordered should be increased by ≈ 15%  
Für die Trockenverlegung muss in der Bestellung eine Menge von ≈ 15% zusätzlich vorgesehen werden | Pour pose à sec, prévoir dans la commande une quantité de pierre majorée de ≈ 15%

\*Giunto compreso | Joint included | einschließlich Fuge | joint compris ± 5%





# “Vintage

*Un rivestimento composto da tavole ispirate ai vecchi ponteggi per rispondere alle tendenze contemporanee dell'architettura di interni, riproponendo un passato umile in chiave moderna e ricercata. Vintage è un omaggio al lavoro che diventa arte nelle mani degli artigiani, un richiamo all'abilità manuale e alla creatività del fare che si esprime in innumerevoli forme e mestieri.*

*A cladding made up of boards inspired by old scaffolding so that to respond to contemporary trends in interior architecture and still re-propose a humble past through a modern and refined key. Vintage is a tribute to work which becomes art in the hands of craftsmen, a reference to manual skills and to the creativity of doing, expressed in countless shapes and crafts.*

*Eine Verkleidung aus Leisten, die von einem alten Baugerüst inspiriert wurde, um auf die zeitgenössischen Trends in der Innenarchitektur zu reagieren und eine bescheidene Vergangenheit in einer modernen, extravaganen Form wieder aufleben zu lassen. Vintage ist eine Hommage an die Arbeit, die in den Händen von Handwerkern zur Kunst wird, eine Erinnerung an das handwerkliche Geschick und die Kreativität der Herstellung, die in unzähligen Formen und Berufen zum Ausdruck kommt.*

*Un revêtement composé de planches inspirées d'anciens échafaudages pour répondre aux tendances contemporaines de l'architecture d'intérieur, reproposant un passé humble dans une clé moderne et raffinée. Vintage est un hommage au travail qui devient de l'art entre les mains des artisans, une référence à l'habileté manuelle et à la créativité du faire qui s'exprime dans d'innombrables formes et métiers.*

# Vintage



CARAMEL



MOKA



CENERE



VANILLA

ELEMENTI PIANI | FLAT ELEMENTS  
FLACHE ELEMENTE | ÉLÉMENTS PLATS

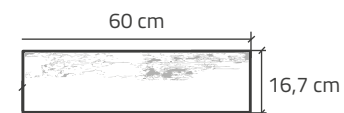

## SPECIFICHE DI PRODOTTO - PRODUCT SPECIFICATIONS - ANGABEN ZUM PRODUKT - CARACTÉRISTIQUES DU PRODUIT

	DIMENSIONI DIMENSIONS ABMESSUNGEN DIMENSIONS	ALTEZZA HEIGHT HÖHE HAUTEUR	LUNGHEZZA LENGHT LÄNGE LONGUEUR	PESO A CONFEZIONE WEIGHT PER BOX GEWICHT/PACKUNG POIDS PAR BOÎTE	CONFEZIONE PACKAGING PACKUNG BOÎTE	SPESSORE THICKNESS DICKE ÉPAISSEUR	POSA INSTALLATION VERLEGUNG POSE
<b>ELEMENTI PIANI FLAT ELEMENTS FLACHE ELEMENTE ÉLÉMENTS PLATS</b>	≈ 1002,00 cm <sup>2</sup>	≈ 16,70 cm	≈ 60,00 cm	≈ 32,00 kg (32,00 kg/m <sup>2</sup> )	1,00 m <sup>2</sup> (36,00 m <sup>2</sup> /pallet)	≈ 2,50 cm	a secco dry stacked trocken joint sec

RESA - YIELD - VERBRAUCH - RENDEMENT: ARREDOCOLLA 6-7 kg/m<sup>2</sup>



Vintage Cenere



Vintage Caramel



Vintage Vanilla





# “Toga

*Ispirato alla trama dei tronchetti d'acero spaccati e rifilati, Toga, con le sue superfici irregolari e i suoi piani sfalsati, conferisce una naturale tridimensionalità alle pareti, lasciando entrare la natura in ogni ambiente. Questo rivestimento è disponibile sia nei colori naturali, che creano atmosfere classiche e delicate, sia in versione metallica per impreziosire le stanze dal design più ricercato e particolare.*

*Inspired by the texture of split and trimmed maple logs, Toga, with its irregular surfaces and staggered planes, gives a natural three-dimensionality to walls, thus letting nature get in every space. This cladding is available in natural colours, which create classic and delicate atmospheres, and also in a metallic version so that to embellish the rooms with a more refined and particular design.*

*Inspiriert durch das Geflecht von gespaltenen und wieder zusammengesetzten Ahornstämmen, verleiht Toga mit seinen unregelmäßigen Oberflächen und versetzten Ebenen den Wänden eine natürliche Dreidimensionalität und füllt jeden Raum mit Natur. Diese Verkleidung ist sowohl in natürlichen Farben erhältlich, die eine klassische und zarte Atmosphäre schaffen, als auch in einer metallischen Version, um Räume mit einem anspruchsvollen und besonderen Design zu verschönern.*

*Inspiré par la texture des bûches d'érable fendues et taillées, Toga, avec ses surfaces irrégulières et ses plans décalés, apporte une tridimensionnalité naturelle aux murs, laissant la nature entrer dans chaque quel environnement. Ce revêtement est disponible soit dans des couleurs naturelles, qui créent des atmosphères classiques et délicates, soit dans une version métallique pour embellir les pièces avec un design plus raffiné et particulier.*

# Toga



CARAMEL



MOKA



CENERE



TITANIO\*



PLATINO\*



ARDESIA\*



GRAFITE\*



GOLD\*



BASIC\*\*

ELEMENTI PIANI  
FLAT ELEMENTS  
FLACHE ELEMENTE  
ÉLÉMENTS PLATS

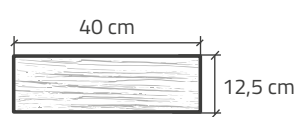
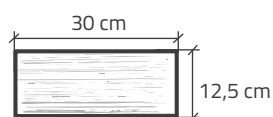
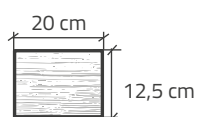

ELEMENTI ANGOLARI  
CORNER ELEMENTS  
ECKELEMENTE  
ÉLÉMENTS D'ANGLE

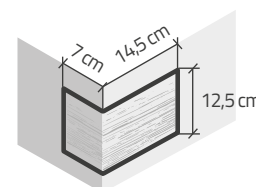

## SPECIFICHE DI PRODOTTO - PRODUCT SPECIFICATIONS - ANGABEN ZUM PRODUKT - CARACTÉRISTIQUES DU PRODUIT

	DIMENSIONI DIMENSIONS ABMESSUNGEN DIMENSIONS	ALTEZZA HEIGHT HÖHE HAUTEUR	LUNGHEZZA LENGHT LÄNGE LONGUEUR	PESO A CONFEZIONE WEIGHT PER BOX GEWICHT/PACKUNG POIDS PAR BOÎTE	CONFEZIONE PACKAGING PACKUNG BOÎTE	SPESSORE THICKNESS DICKE ÉPAISSEUR	POSA INSTALLATION VERLEGUNG POSE
<b>ELEMENTI PIANI FLAT ELEMENTS FLACHE ELEMENTE ÉLÉMENTS PLATS</b>	da 250,00 cm <sup>2</sup> a 500,00 cm	≈ 12,50 cm	≈ 20,00 cm ≈ 30,00 cm ≈ 40,00 cm	≈ 16,00 kg (32,00 kg/m <sup>2</sup> )	0,50 m <sup>2</sup> (20,00 m <sup>2</sup> /pallet)	≈ 3,00 cm	a secco dry stacked trocken joint sec
<b>ELEMENTI ANGOLARI CORNER ELEMENTS ECKELEMENTE ÉLÉMENTS D'ANGLE</b>	-	≈ 12,50 cm	da 7,00 cm a 14,50 cm	≈ 8,50 kg	1,00 m (40,00 m/pallet)	≈ 3,00 cm	

RESA - YIELD - VERBRAUCH - RENDEMENT: ARREDOCOLLA 6-7 kg/m<sup>2</sup>

\* per interni | for interiors | für Innen | pour interne

\*\* La versione BASIC può essere pitturata con qualsiasi tipo di pittura. | The Basic versione can be painted with any kind of paint.  
Die Basisversion kann mit jeder Art Farbe gestrichen werden. | La version BASIC peut être peinte avec n'importe quel type de peinture.



**Toga Ardesia**



**Toga Grafite**



**Toga Moka**



**Toga Platino**



# “Victory

*Fasce ondulate a rilievo come quelle dell'argilla plasmata dal fiume creano un effetto di chiaroscuro sulla superficie di Victory, un rivestimento da osservare con il tatto e da sfiorare con gli occhi. Le colorazioni metalliche, con la loro elegante lucentezza, conferiscono a Victory una raffinatezza quasi regale che nobilita la sua ruvidezza.*

*Wavy bands in relief, such as those of clay moulded by the river, create a chiaroscuro effect on the surface of Victory, a cladding to be observed through hands and to be touched through eyes. The metallic colours, with their elegant brilliance, give Victory an almost regal refinement which ennobles its roughness.*

*Wellenförmige, reliefartige Bänder, die wie vom Fluss geformter Ton aussehen, erzeugen einen Hell-Dunkel-Effekt auf der Oberfläche von Victory, eine Verkleidung, die man mit den Augen entdecken und mit dem Tastsinn wahrnehmen kann. Die metallischen Farben mit ihrem eleganten Glanz verleihen Victory eine fast königliche Raffinesse, die seine Rauheit veredelt.*

*Des bandes ondulées en relief telles que celles de l'argile façonnée par la rivière créent un effet de clair-obscur à la surface de Victory, un revêtement à observer au toucher et à effleurer avec les yeux. Les couleurs métalliques, avec leur éclat élégant, donnent à Victory un raffinement presque royal qui ennoblit sa rugosité.*

# Victory



GOLD\*

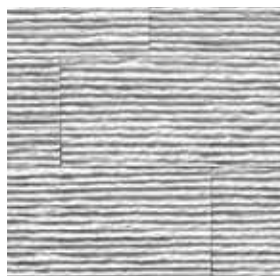

PLATINO\*

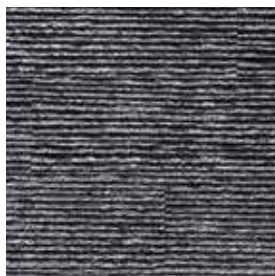

GRAFITE\*

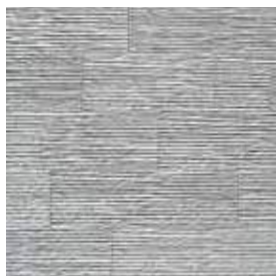

BASIC\*\*

ELEMENTI PIANI | FLAT ELEMENTS  
FLACHE ELEMENTE | ÉLÉMENTS PLATS

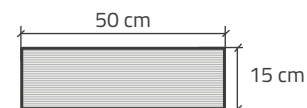

ELEMENTI ANGOLARI | CORNER ELEMENTS  
ECKELEMENTE | ÉLÉMENTS D'ANGLE

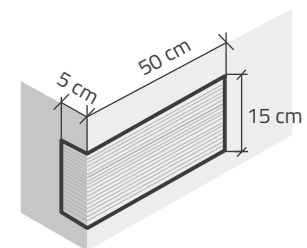

## SPECIFICHE DI PRODOTTO - PRODUCT SPECIFICATIONS - ANGABEN ZUM PRODUKT - CARACTÉRISTIQUES DU PRODUIT

	DIMENSIONI DIMENSIONS ABMESSUNGEN DIMENSIONS	ALTEZZA HEIGHT HÖHE HAUTEUR	LUNGHEZZA LENGHT LÄNGE LONGUEUR	PESO A CONFEZIONE WEIGHT PER BOX GEWICHT/PACKUNG POIDS PAR BOÎTE	CONFEZIONE PACKAGING PACKUNG BOÎTE	SPESSORE THICKNESS DICKE ÉPAISSEUR	POSA INSTALLATION VERLEGUNG POSE
<b>ELEMENTI PIANI FLAT ELEMENTS FLACHE ELEMENTE ÉLÉMENTS PLATS</b>	≈ 750,00 cm <sup>2</sup>	≈ 15,00 cm	≈ 50,00 cm	≈ 19,00 kg (32,00 kg/m <sup>2</sup> )	0,60 m <sup>2</sup> (25,20 m <sup>2</sup> /pallet)	≈ 2,50 cm	a secco dry stacked trocken joint sec
<b>ELEMENTI ANGOLARI CORNER ELEMENTS ECKELEMENTE ÉLÉMENTS D'ANGLE</b>	-	≈ 15,00 cm	5,00-50,00 cm	≈ 9,80 kg	0,90 m (72,00 m/pallet)	≈ 2,50 cm	

RESA - YIELD - VERBRAUCH - RENDEMENT: ARREDOCOLLA 6-7 kg/m<sup>2</sup> / ARREDOSTUCCO 8-10 kg/m<sup>2</sup>

\* per interni | for interiors | für Innen | pour interne

\*\* La versione BASIC può essere pitturata con qualsiasi tipo di pittura. | The Basic version can be painted with any kind of paint.  
Die Basisversion kann mit jeder Art Farbe gestrichen werden. | La version BASIC peut être peinte avec n'importe quel type de peinture.

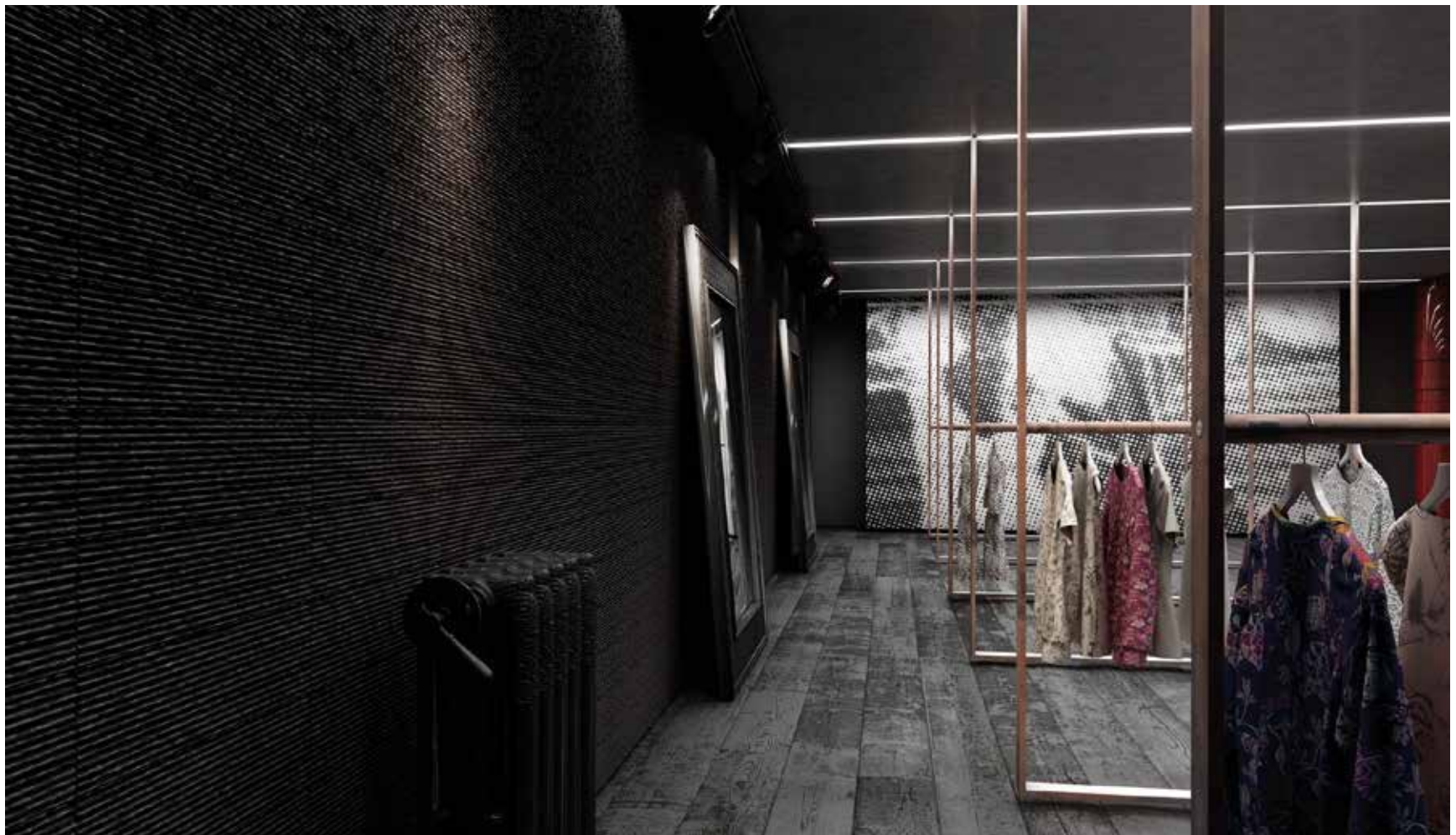

Victory Grafite



Victory Platino

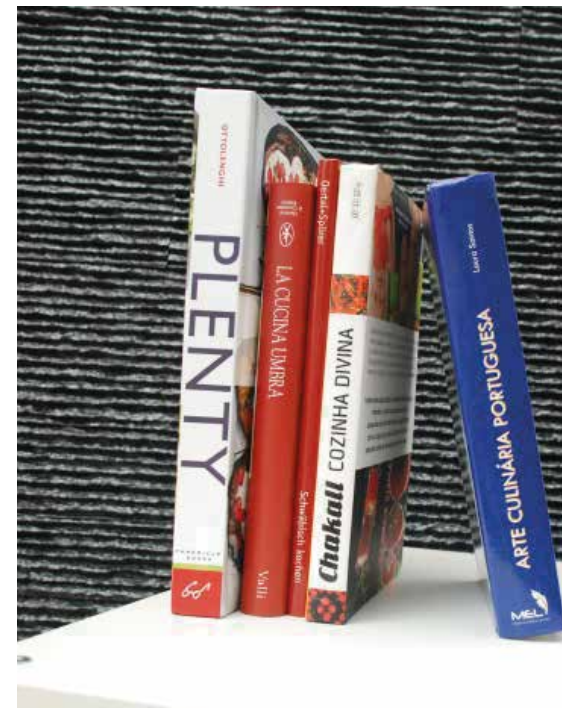

Victory Grafite

# Elemento Aqva

SABBIA

**SPECIFICHE DI PRODOTTO - PRODUCT SPECIFICATIONS  
ANGABEN ZUM PRODUKT - CARACTÉRISTIQUES DU PRODUIT**

	DIMENSIONI DIMENSIONS ABMESSUNGEN DIMENSIONS	PESO A PEZZO WEIGHT PER PIECE GEWICHT PRO STÜCK POIDS PAR PIECE	PESO A SCATOLA WEIGHT PER BOX GEWICHT PRO SCHACHTEL POIDS PAR BOÎTE
<b>ELEMENTI PIANI FLAT ELEMENTS FLACHE ELEMENTE ÉLÉMENTS PLATS</b>	25,00 x 31,00 cm	≈ 4,70 cm	≈ 24,00 kg ( Nr. 5 pz)



# Elemento Savana

SABBIA

**SPECIFICHE DI PRODOTTO - PRODUCT SPECIFICATIONS  
ANGABEN ZUM PRODUKT - CARACTÉRISTIQUES DU PRODUIT**

	DIMENSIONI DIMENSIONS ABMESSUNGEN DIMENSIONS	PESO A PEZZO WEIGHT PER PIECE GEWICHT PRO STÜCK POIDS PAR PIECE	PESO A SCATOLA WEIGHT PER BOX GEWICHT PRO SCHACHTEL POIDS PAR BOÎTE
<b>ELEMENTI PIANI FLAT ELEMENTS FLACHE ELEMENTE ÉLÉMENTS PLATS</b>	40,00 x 50,00 cm	≈ 18,00 cm	≈ 18,00 kg





# Kronos

BIANCO / GRIGIO TERRA / SABBIA / GRIGIO



BIANCO



GRIGIO TERRA



SABBIA



GRIGIO



## SPECIFICHE DI PRODOTTO - PRODUCT SPECIFICATIONS ANGABEN ZUM PRODUKT - CARACTÉRISTIQUES DU PRODUIT

DIMENSIONI DIMENSIONS ABMESSUNGEN DIMENSIONS	PESO A PEZZO WEIGHT PER PIECE GEWICHT PRO STÜCK POIDS PAR PIÈCE	PESO A SCATOLA WEIGHT PER BOX GEWICHT PRO SCHACHTEL POIDS PAR BOÎTE
30,00 x 30,00 cm	≈ 11,00 kg	≈ 11,00 kg

# Terminale

BIANCO / CREMA / GRIGIO TERRA / SABBIA / GRIGIO CHIARO

BIANCO



CREMA



GRIGIO TERRA



SABBIA



GRIGIO CHIARO



## SPECIFICHE DI PRODOTTO - PRODUCT SPECIFICATIONS - ANGABEN ZUM PRODUKT - CARACTÉRISTIQUES DU PRODUIT

	DIMENSIONI DIMENSIONS ABMESSUNGEN DIMENSIONS	PESO A SCATOLA WEIGHT PER BOX GEWICHT/SCHACHTEL POIDS PAR BOÎTE	PESO A PEZZO WEIGHT PER PIECE GEWICHT/STÜCK POIDS PAR PIÈCE	SPESSORE THICKNESS DICKE ÉPAISSEUR	POSA INSTALLATION VERLENGUNG POSE
<b>ELEMENTI PIANI FLAT ELEMENTS FLACHE ELEMENTE ÉLÉMENTS PLATS</b>	50,00 x 7,00 cm	≈ 20,00 kg	≈ 2,50 kg		fugato grouted mit Fuge avec joint
<b>ELEMENTI ANGOLARI CORNER ELEMENTS ECKSTEINE ÉLÉMENTS D'ANGLES</b>		27,60 kg	≈ 2,30 kg		



# Sistema Integrato

*I nostri elementi di finitura vengono forniti in un unico sistema integrato con prodotti studiati e creati appositamente per la realizzazione di un'opera realistica, tecnicamente valida ed efficiente che prevede l'utilizzo dell'adesivo rasante **ARREDOCOLLA**, il rivestimento in pietra o mattoni ricostruiti **PIETRE D'ARREDO** e la malta naturale per la stuccatura delle fughe **ARREDOSTUCCO**.*

## **Integrated System**

*Our finishing elements are supplied in a sole integrated system with products specifically designed and manufactured to provide a realistic, technically valid and efficient piece of work that includes the use of the smoothing adhesive **ARREDOCOLLA**, the **PIETRE D'ARREDO** reconstructed stone facing and the natural mortar for grouting **ARREDOSTUCCO**.*

## **Integriertes System**

*Unsere Elemente werden in Form eines Integriertem Systems geliefert, mit Produkten die speziell für die Erstellung einer realistischen Arbeit entwickelt und hergestellt wurden, technischer hochstand und effizient diese beinhaltet die Verwendung des **ARREDOCOLLA** unser Kleber der für das Glätten geeignet ist, die Kunststeine oder Kunstziegeln Verblendungen **PIETRE D'ARREDO** und die natürliche Mörtel **ARREDOSTUCCO** für die Spachtelung der Fugen.*

## **Système Intégré**

*Nos éléments sont fournis dans un système unique intégré avec des produits étudiés et créés spécialement pour la réalisation d'un ouvrage réaliste, techniquement valide et efficace qui prévoit l'emploi de l'adhésif enduit **ARREDOCOLLA**, le revêtement en pierre ou briques reconstitués **PIETRE D'ARREDO** et le mortier naturel pour le jointoiment des joints **ARREDOSTUCCO**.*

# Arredocollo

## Perché ARREDOCOLLA?

ARREDOCOLLA è composto da leganti idraulici, cariche minerali selezionate e additivi speciali che ne migliorano la lavorabilità e contribuiscono a ridurre la formazione di efflorescenze sulla superficie della pietra e dei mattoni ricostruiti, a differenza degli adesivi comunemente utilizzati in edilizia. Garantisce una perfetta adesione su tutti i supporti cementizi di normale uso in edilizia e assenza di scivolamento verticale, anche in caso di posa di elementi di grandi dimensioni. Ad indurimento avvenuto, presenta ottime proprietà meccaniche, flessibilità e ottima permeabilità al vapore: tutte queste specifiche, rendono ARREDOCOLLA l'unico adesivo perfettamente compatibile con le pietre e i mattoni ricostruiti Pietre d'Arredo, esaltandone anche le caratteristiche tecniche.

## Why ARREDOCOLLA?

ARREDOCOLLA consists of hydraulic binders, selected mineral fillers and special additives that improve workability and help reduce the formation of efflorescence on the surface of reconstructed stone tiles and bricks, unlike the adhesives commonly used in the building industry. It ensures perfect adhesion on all cement-based substrates normally used in the building industry and no vertical slip, even where laying large elements. Once hardened, it has outstanding mechanical properties, flexibility and excellent steam permeability: all these specifications make ARREDOCOLLA the only adhesive perfectly compatible with Pietre d'Arredo reconstructed stone and bricks, also enhancing their technical characteristics.

## Warum ARREDOCOLLA?

ARREDOCOLLA besteht aus hydraulischen Bindemitteln, ausgewählten Mineral Füllstoffe und speziellen Zusatzstoffe, die die Verarbeitung verbessern und zur Reduzierung von Ausblühungen auf den Oberflächen des Kunststeines und Kunstziegeln beitragen, im Gegensatz zu den anderen die allgemein im Baufach benutzt werden. Das Produkt gewährleistet perfekte Haftung auf allen Zement Untergründe, die gewöhnlich im Baufach eingesetzt werden, ohne vertikales verrutschen auch bei Verlegung von großen Elemente. Nach erfolgter Aushärtung entstehen ausgezeichnete mechanische Merkmale, Flexibilität und optimale Dampf Durchlässigkeit: Dank all diesen Merkmale ist ARREDOCOLLA der einzige Kleber, der mit den Kunststeine und Kunstziegeln von Pietre d'Arredo kompatibel ist und der deren technischen Eigenschaften noch mehr hervorhebt.

## Pourquoi ARREDOCOLLA?

ARREDOCOLLA est composé de liants hydrauliques, de charges minérales sélectionnées et d'additifs spéciaux qui améliorent son ouvrabilité et contribuent à réduire la formation d'efflorescences sur la surface de la pierre et des briques reconstituées, contrairement aux adhésives communément utilisés dans les bâtiments. Il garantit une adhésion parfaite sur tous les supports à base de ciment d'usage normal dans le bâtiment et l'absence de glissement vertical, même en cas de pose d'éléments de grands formats. Après le durcissement, il présente des propriétés mécaniques optimales ainsi qu'une flexibilité et une perméabilité à la vapeur excellentes: toutes ces spécificités font d'ARREDOCOLLA le seul adhésif parfaitement compatible avec les pierres et briques reconstituées Pietre d'Arredo, en exaltant même leurs caractéristiques techniques.



GRIGIO



CREMA



MARRONE  
CHIARO

Adesivo rasante professionale in polvere a base di leganti minerali, ad elevate prestazioni, scivolamento verticale nullo, per la posa di pietre e mattoni ricostruiti. Resa: 6-7 kg/m<sup>2</sup> a seconda del tipo di supporto.

High performance professional smoothing adhesive composed of mineral binders, no vertical slip, for reconstructed stone and brick laying. Yield: 6-7 kg/m<sup>2</sup> according to the kind of support.

Putz-Kleber aus mineralischen Bindemitteln für professionellen Gebrauch, mit höchster Leistung, ohne vertikales Verrutschen, für die Verlegung von Kunststein und Kunstziegeln. Verbrauch: 6-7 kg/m<sup>2</sup>, je nach Untergrund.

Colle-enduit de lissage professionnelle à base de liants minéraux, hautes performances, glissement vertical nul, pour la pose de pierres et briques reconstituées. Rendement: 6-7 kg/m<sup>2</sup> en fonction du type de support.

# Arredostucco

## Perché ARREDOSTUCCO?

Con ARREDOSTUCCO si realizzano stuccature caratterizzate da ottima resistenza agli agenti atmosferici, ottima resistenza alla formazione di efflorescenze, basso assorbimento di acqua e alta traspirabilità. Le diverse colorazioni ed i diversi gradi di finitura sono stati studiati per esaltare l'aspetto estetico del rivestimento ed integrarsi perfettamente con i diversi modelli di pietra ricostruita Pietre d'Arredo. La stuccatura del rivestimento in pietra ricostruita è parte integrante e fondamentale per il risultato finale dell'opera. Il colore dello stucco, la quantità nella fuga e le diverse tecniche di lavorazione determineranno l'unicità e la credibilità della parete in pietra ricostruita.

## Why ARREDOSTUCCO?

Use ARREDOSTUCCO to obtain grouting with excellent resistance to atmospheric agents and efflorescence formation, low water absorption and high breathability. The available different colours and finishing degrees as well as great processing versatility enhance the aesthetic appearance of the coating, having been precisely designed to highlight and perfectly integrate with the various models of Pietre d'Arredo reconstructed stone. The grouting of reconstructed stone covering is an integral key element to the final result of the work. The grout colour and the quantity in the joint as well as the different processing techniques will determine the uniqueness and credibility of the reconstructed stone wall.

## Warum ARREDOSTUCCO?

Mit ARREDOSTUCCO erzielt man Spachtelungen mit ausgezeichneter Festigkeit gegenüber Witterungseinflüssen und gegenüber der Bildung von Ausblühungen, niedrigem Wasseraufnahmegrad und hohe Atmungsaktivität. Die verschiedenen Farben, die unterschiedlichen Grade des Finishes, die Vielseitigkeit in Bezug auf die möglichen Verarbeitungen dienen zur Optimierung des Erscheinungsbild der Verkleidung und wurden entwickelt um die verschiedenen Modelle des Kunststeines Pietre d'Arredo zu ergänzen. Die Spachtelung des Kunststeines ist ein sehr wichtiger Teil für das Endergebnis des Bauwerkes. Die Farbe der Fugenmasse, die Menge und die verschiedenen Verarbeitungstechniken sind für das einzigartige Aussehen und für die Glaubwürdigkeit der Wand ausschlaggebend.

## Pourquoi ARREDOSTUCCO?

ARREDOSTUCCO permet de réaliser un jointoiment caractérisé par une résistance parfaite aux agents atmosphériques et à la formation d'efflorescences, une faible absorption d'eau et une transpirabilité élevée. Les différentes tonalités, les différents degrés de finition, la polyvalence dans les traitements possibles ont été étudiés pour exalter l'aspect esthétique du revêtement et pour s'intégrer parfaitement avec les différents modèles de pierre reconstituée Pietre d'Arredo. Le jointoiment du revêtement en pierre reconstituée constitue une partie intégrante et fondamentale du résultat final de l'ouvrage. La couleur du mortier de jointoiment, la quantité dans le joint et les différentes techniques de traitement détermineront l'unicité et l'aspect authentique des parois en pierre reconstituée.

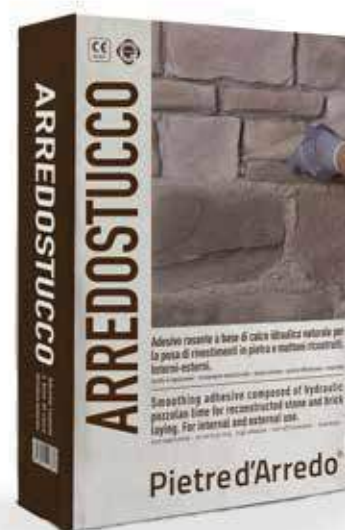

25 kg



\* Disponibile in grana fine · Available in fine grain  
Ebenfalls feinkörnig verfügbar · Disponible en grain fin

Malta naturale colorata per la stuccatura ad alta traspirabilità di rivestimenti in pietra e mattoni ricostruiti. Resa: 8-12 kg/m<sup>2</sup> a seconda delle fughe.

Coloured natural mortar for high transpirability grouting of reconstructed stone and brick covering. Yield: 8-12 kg/m<sup>2</sup> depending on the joints.

Natürlicher, farbiger Mörtel für einen Verputz mit hoher Atmungsaktivität bei Belägen aus Kunststein und Kunstziegeln. Verbrauch: 8-12 kg/m<sup>2</sup> je nach den Fugen.

Mortier naturel coloré pour le jointoiment à haute transpirabilité de revêtements en pierres et briques reconstituées. Rendement: 8-12 kg/m<sup>2</sup> selon les joints.

# Arredofix

**\* per cartongesso / onto plasterboard walls / für Gipsplatte / sur pacoplâtre**

Adesivo in pasta ad elevate prestazioni pronto all'uso per la posa di pietre e mattoni ricostruiti. Da utilizzare per la posa su cartongesso. Resa: 3-4 kg/m<sup>2</sup> a seconda del tipo di supporto.

High performance ready-to-use adhesive paste for wall coverings laying of reconstructed stones and bricks. To be used for the laying onto plasterboard walls. Yield: 3-4 kg/m<sup>2</sup> according to the kind of support.

Sofort einsatzbereiter Pastenkleber mit höchster Leistung für die Verlegung von Kunststein und Kunstziegeln. Auf Verlegung von Gipsplatte benutzen. Verbrauch: 3-4 kg/m<sup>2</sup> je nach Untergrund.

Adhésif en pâte à hautes prestations prêt à l'usage pour la pose de pierres et briques reconstituées. À utiliser pour la pose sur placoplâtre. Rendement: 3-4 kg/m<sup>2</sup> selon le type de support.



8 kg

20 kg



BIANCO

# Arredolight 0-3 mm / 0-6 mm

**\* per cappotto / for thermal insulation systems / Wärmedämmverbundsysteme / sur pacoplâtre**

Inerte leggero da miscelare con ARREDOSTUCCO per la stuccatura di fughe tra pietre ricostruite. Aumenta la resa, favorisce la pulizia, migliora la traspirabilità e riduce i ponti termici. Da utilizzare per la posa su cappotto. Rapporto di miscelazione: 1 sacco di ARREDOSTUCCO (25 kg) + 1 sacco di ARREDOLIGHT (7,5 L).

Lightweight aggregate to be mixed with ARREDOSTUCCO for grouting reconstructed stone coverings. It increases the yield, helps cleaning, improves breathability and reduces thermal bridges. To be used for the laying of thermal insulation systems. Mixing ratio: 1 bag of ARREDOSTUCCO (25 kg) + 1 bag of ARREDOLIGHT (7,5 L).

Ausgewählter Leichtzuschlagstoff zum Vermischen mit dem Fugenmörtel ARREDOSTUCCO, für die Füllung zwischen den Kunststeinen. Erhöht die Leistung, hilft die Steinfläche sauber zu erhalten, verbessert die Atmungsfähigkeit, vermindert die Wärmebrücken. Auf Verlegung von Wärmedämmverbundsysteme benutzen. Mischungsverhältnis: 1 Sack ARREDOSTUCCO (25 kg) + 1 Sack ARREDOLIGHT (7,5 L).

Constituant inerte léger à mélanger avec ARREDOSTUCCO pour le jointoiment de pierres reconstituées. Il augmente le rendement, facilite le nettoyage, améliore la transpirabilité et réduit les ponts thermiques. À utiliser pour la pose sur isolant thermique. Rapport de mélange: 1 sac de ARREDOSTUCCO (25 kg) + 1 sac de ARREDOLIGHT (7,5 L).



7,5 L  
ca. 5 kg



BIANCO

# Sacchetti Triangolari

Sacchetti triangolari usa e getta in polietilene e sacchetti in poliuretano leggero professionale per iniettare lo stucco nei giunti di pietre e mattoni.

Disposable triangular polyethylene bags and professional triangular light polyurethane bag for grout injecting into stone and brick joints.

Einweg-Dreiecksbeutel aus Polyethylen und professionelle leichte Polyurethan-Beutel zum Einspritzen von Kitt in Stein- und Ziegelverbindungen.

Sacs triangulaires jetables en polyéthylène et sacs en polyuréthane léger professionnel pour injecter du stuc dans les joints de pierres et de briques.



## Armoflex 330

Rete tecnologica in fibra di vetro apprettata con elevata protezione agli alcali. Ideale per armare e rinforzare nei sistemi di isolamento a cappotto e su fondi con scarsa resistenza meccanica. Alta resistenza a trazione e al carico di rottura. Peso: 330 g/m<sup>2</sup>.

Fibreglass technological mesh primed for high alkali resistance. Suitable to strengthen and reinforce insulation systems onto substrates with low mechanical resistance. High tensile strength and breaking load. Weight: 330 g/m<sup>2</sup>.

Technologisches Glasfasernetz appetiert für einen hohen Schutz gegen Alkalien. Zur verstärkenden Armierung und Wärmedämmungsverkleidung und für Steigerung des mechanischen Widerstands des realisierten Belags, auch bei kritischen Betriebssituationen. Ausgezeichneter Widerstand gegen Zugbelastung und Zugfestigkeit. Gewicht: 330 g/m<sup>2</sup>.

Treillis technologique en fibre de verre apprêté pour une haute protection contre les alcalis. Idéal comme armature de renfort pour systèmes d'isolation à manteau et sur fonds avec basse résistance mécanique. Haute résistance à la traction et à la charge de rupture. Poids: 330 g/m<sup>2</sup>.



50 m<sup>2</sup>

## Arredosil

Impregnante siliconico incolore a base acquosa per la protezione idrorepellente di rivestimenti in pietra e mattoni ricostruiti. Resa: 0,250 kg/m<sup>2</sup>.

Water based colourless silicone solution for water repellent protective treatment of reconstructed stone and brick facings. Yield: 0.250 kg/m<sup>2</sup>.

Farblose Silikonimprägnierungsmittel auf Wasserbasis für erhöhte Wasserabweiskraft von Wandbelägen aus Kunststein und Kunstziegeln. Verbrauch: 0,250 kg/m<sup>2</sup>.

Imprégnant silicone incolore à base d'eau pour la protection hydrofuge de revêtements en pierres et briques reconstituées. Rendement: 0,250 kg/m<sup>2</sup>.



5 L

1 L

## Arredocoat

Impregnante ad effetto bagnato per la protezione idrorepellente di rivestimenti in pietra e mattoni ricostruiti. Resa: 0,250 kg/m<sup>2</sup>.

Impregnating agent conferring wet effect and water-repellence to reconstructed stone and brick facings. Yield: 0.250 kg/m<sup>2</sup>.

Imprägnierungsmittel mit optischem Feuchtigkeitseffekt für erhöhte Wasserabweiskraft von Wandbelägen aus Kunststein und Kunstziegeln. Verbrauch: 0,250 kg/m<sup>2</sup>.

Imprégnant à effet mouillé pour la protection hydrofuge de revêtements en pierres et briques reconstituées. Rendement: 0,250 kg/m<sup>2</sup>.



5 L

1 L





## Sistemi Innovativi

*La nostra esperienza e la ricerca continua ci ha portato a sviluppare sistemi ad hoc: **PIETRA COMFORT**, per la posa dei nostri rivestimenti in pietra e mattoni ricostruiti su pannelli termoisolanti nella realizzazione di sistemi di isolamento termico; **AIR SYSTEM**, per la posa dei nostri rivestimenti in pietra e mattoni ricostruiti su superfici soggette alla risalita di umidità per capillarità.*

### **Innovative systems**

*Our experience and continuous research has led us to develop ad hoc systems: **PIETRA COMFORT**, for the installation of our reconstructed stone and brick coverings on thermal insulation panels in the construction of thermal insulation systems; **AIR SYSTEM**, for the laying of our reconstructed stone and brick coverings on surfaces subject to moisture rise by capillarity.*

### **Innovative Systeme**

*Unsere Erfahrung und kontinuierliche Forschung hat uns zur Entwicklung von Ad-hoc-Systemen geführt: **PIETRA COMFORT**, für die Verlegung unserer Verkleidungen aus Stein und rekonstruierten Ziegeln auf Wärmedämmplatten bei der Realisierung von Wärmedämmsystemen; **AIR SYSTEM**, für die Verlegung unserer Verkleidungen aus Stein und rekonstruierten Ziegeln auf Oberflächen, die aufgrund ihrer Kapillarität einem Feuchtigkeitsanstieg ausgesetzt sind.*

### **Systèmes Innovants**

*Notre expérience et notre recherche continue nous ont conduits à développer des systèmes ad hoc: **PIETRA COMFORT**, pour la pose de nos revêtements en pierres et briques reconstituées sur panneaux thermo-isolants pour la réalisation de systèmes d'isolation thermique; **AIR SYSTEM**, pour la pose de nos revêtements en pierres et briques reconstituées sur des surfaces sujettes à la remontée d'humidité par capillarité.*

# Pietra Comfort

*Sistema garantito per la posa di rivestimenti in pietra e mattoni ricostruiti su isolamenti termici esterni di edifici.*

*High security system for the installation of reconstructed stone and brick facings on external thermal insulation of buildings.*

*Hochwertiges System für die Verlegung von Wandbelägen aus Kunststein und Kunstziegeln auf Thermoisolierungen bei Gebäudefronten.*

*Système offrant une garantie élevée pour la pose de revêtements en pierres et briques reconstituées sur isolations thermiques extérieures de bâtiments.*

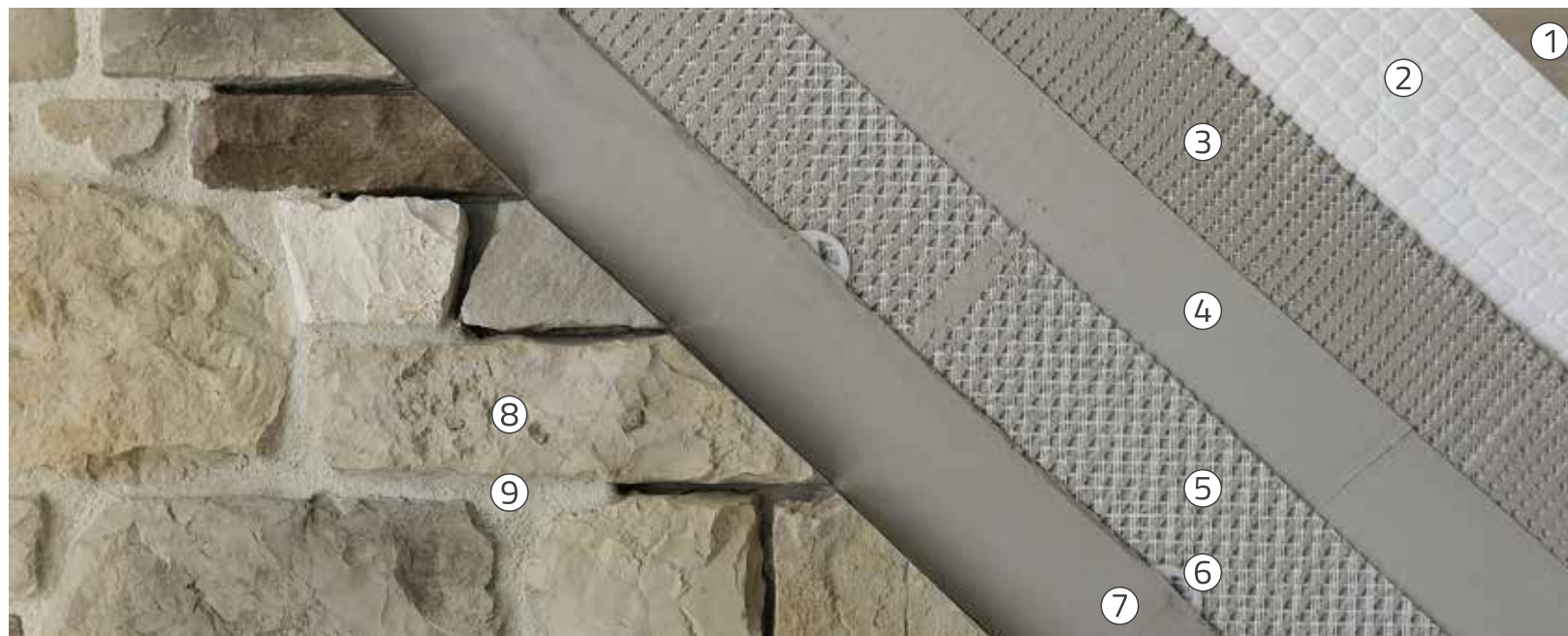

1. Supporto cementizio  
 2. Pannello termoisolante  
 3. Adesivo rasante minerale per la rasatura di pannelli termoisolanti, con interposta armatura in fibra di vetro  
 4. Adesivo rasante minerale per pannelli termoisolanti -2° strato  
 5. ARREDOCOLLA adesivo rasante con interposta rete di armatura rinforzata alcali-resistente ARMOFLEX 330  
 6. Fissaggio meccanico con tasselli ROCKET  
 7. ARREDOCOLLA adesivo rasante-2° strato  
 8. PIETRE D'ARREDO rivestimento in pietra ricostruita posato con ARREDOCOLLA  
 9. ARREDOSTUCCO + ARREDOLIGHT per il riempimento e la sigillatura delle fughe tra gli elementi del rivestimento

1. Cementitious substrate  
 2. Insulating panel  
 3. Mineral smoothing adhesive for the smoothing of insulating panels, with interposed fibreglass reinforcement  
 4. Mineral smoothing adhesive for insulating panels-2nd layer  
 5. ARREDOCOLLA smoothing adhesive, with alkali-resistant interposed reinforcing mesh ARMOFLEX 330  
 6. Mechanical fixing with anchors ROCKET  
 7. ARREDOCOLLA smoothing adhesive-2nd layer  
 8. PIETRE D'ARREDO reconstructed stone facing, laid with ARREDOCOLLA  
 9. ARREDOSTUCCO + ARREDOLIGHT for the filling and the sealing of the joints between the coating elements

1. Betonbelag  
 2. Dämmplatte  
 3. Mineralischer Putz-kleber für die Glättung von Dämmplatten mit eingebettetem Armiergewebe aus Glasfaser  
 4. Mineralischer Putz-kleber für Dämmplatte-2. Schicht  
 5. ARREDOCOLLA Putz-kleber mit eingebettetem alkaliresistenten Stützgewebe ARMOFLEX 330  
 6. Dübel ROCKET  
 7. ARREDOCOLLA Putz-kleber -2.Schicht  
 8. PIETRE D'ARREDO Wandbelag aus Kunststein mit ARREDOCOLLA verlegt  
 9. ARREDOSTUCCO + ARREDOLIGHT für die Füllung und die Versiegelung der Fugen zwischen den Elementen der Verkleidung

1. Support béton  
 2. Panneau isolant  
 3. Colle-enduit minérale de lissage pour le lissage de panneaux isolants, avec armature en fibre de verre interposée  
 4. Colle-enduit minérale de lissage pour panneaux isolants -2ème couche  
 5. ARREDOCOLLA colle-enduit de lissage avec une armature renforcée résistante aux alcalis ARMOFLEX 330  
 6. Fixage mécanique avec ancrage ROCKET  
 7. ARREDOCOLLA colle-enduit de lissage-2ème couche  
 8. PIETRE D'ARREDO parement en pierre reconstituée posé avec ARREDOCOLLA  
 9. ARREDOSTUCCO + ARREDOLIGHT pour le remplissage et le scellage des joints entre les éléments du revêtement

# Air System

*Sistema tecnologico innovativo per la posa di rivestimenti in pietra e mattoni ricostruiti su superfici soggette alla risalita di umidità per capillarità.  
Innovative system for the installation of reconstructed stone and brick facings on surfaces subject to capillary moisture rising.  
Innovatives System für die Verlegung von Wandbelägen aus Kunststein und Kunstziegeln auf Oberflächen, die feinverteilter Feuchtigkeit unterliegen.  
Système innovant pour la pose de revêtements en pierres et briques reconstituées sur surfaces sujettes à la remontée d'humidité par capillarité.*

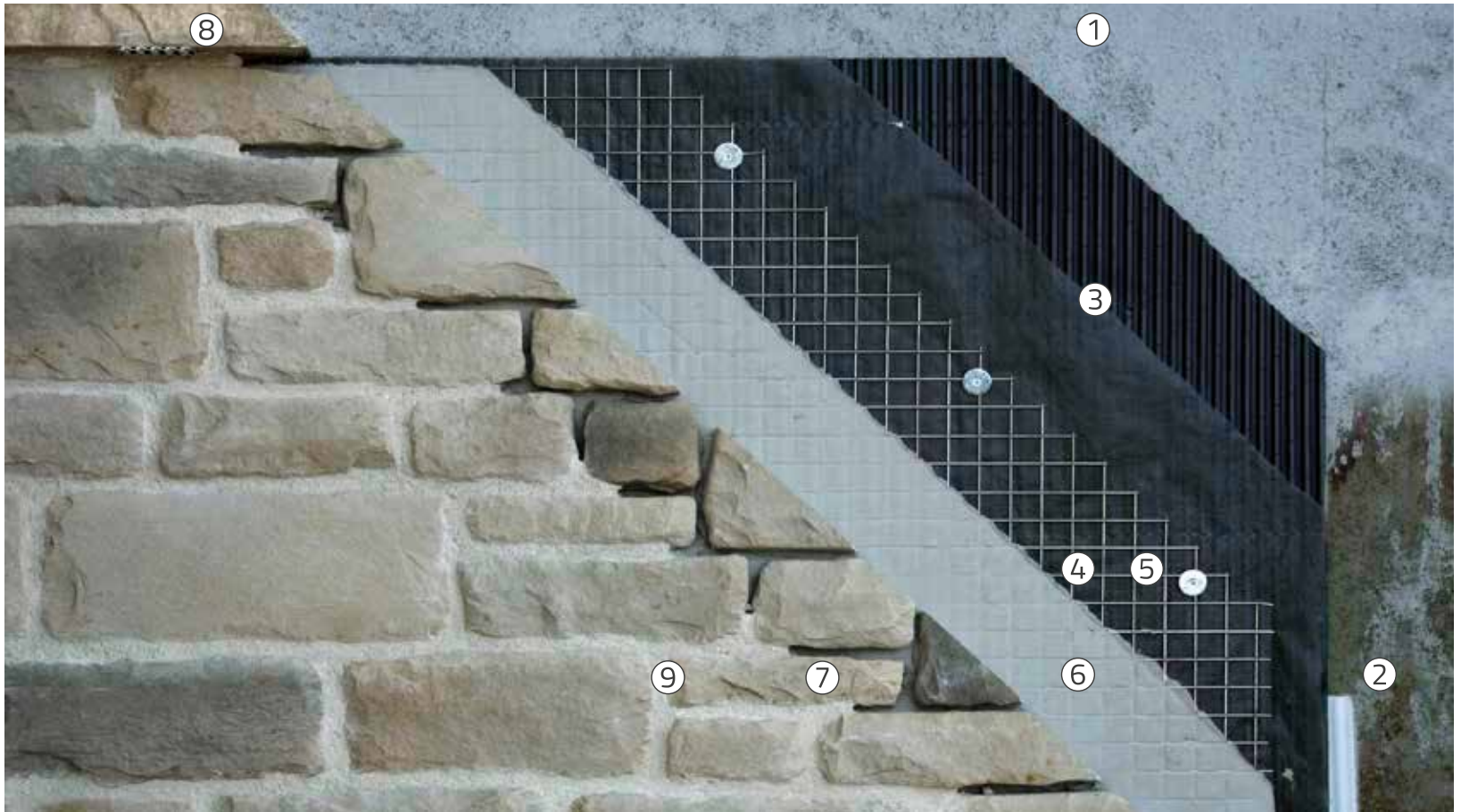

1. Supporto cementizio  
2. Vento "L"  
3. Air plast  
4. Rete zincata  
5. Tasselli di fissaggio  
6. ARREDOCOLLA  
7. PIETRE D'ARREDO  
rivestimento in pietra ricostruita  
8. Terminale  
9. ARREDOSTUCCO  
per il riempimento e la sigillatura  
delle fughe tra gli elementi  
del rivestimento

1. Cementitious substrate  
2. Vento "L"  
3. Air plast  
4. Galvanized mesh  
5. Anchor bolts  
6. ARREDOCOLLA  
7. PIETRE D'ARREDO  
reconstructed stone facings  
8. Terminale  
9. ARREDOSTUCCO  
for the filling and sealing  
of the joints between  
the coating elements

1. Betonbelag  
2. Vento "L"  
3. Air plast  
4. Verzinktes Gitternetz  
5. Befestigungsdübel  
6. ARREDOCOLLA  
7. PIETRE D'ARREDO  
Wandbeläge aus Kunststein  
8. Terminale  
9. ARREDOSTUCCO für die Füllung  
und die Versiegelung der Fugen  
zwischen den Elementen der  
Verkleidung

1. Support béton  
2. Vento "L"  
3. Air plast  
4. Treillis galvanisé  
5. Boulons d'ancrage  
6. ARREDOCOLLA  
7. PIETRE D'ARREDO parement  
en pierre reconstituée  
8. Terminale  
9. ARREDOSTUCCO pour le  
remplissage et le scellage  
des joints entre les éléments  
du revêtement

# Texture Map



**Misto Umbro**

SABBIA

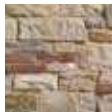

GRIGIO TERRA



BIANCO TERRA

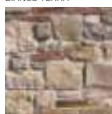

CREMA

**Misto Campagna**

GRIGIO TERRA



GRIGIO CHIARO



CREMA



GRIGIO ANTICO

**Tirolese**

GRIGIO ANTICO



TERRA

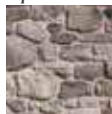

GRIGIO

**Alpino**

GRIGIO CHIARO



TERRA

**Montano**

GRIGIO TERRA

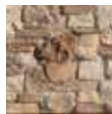

GRIGIO CHIARO

**Dolomite**

MARRONE CHIARO

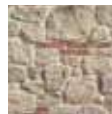

GRIGIO CHIARO

**Canova**

GRIGIO TERRA



GRIGIO CHIARO

**Ligure**

GRIGIO CHIARO



BLU ANTICO

**Toscano**

TERRA

**Veneto**

CREMA

**Etrusco**

TERRA

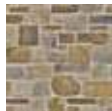
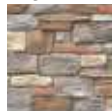
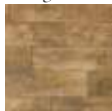
**Cortevocchio****Cortona****Belmonte****Borgonovo****Vintage**

CARAMEL



MOKA



CENERE

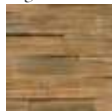

VANILLA

**Toga**

CARAMEL

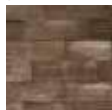

MOKA

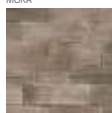

CENERE



TITANIO



PLATINO

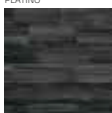

ARDESIA



GRAFITE



GOLD

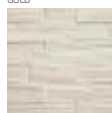

BASIC

**Victory**

GOLD

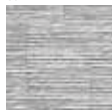

PLATINO



GRAFITE



BASIC

**COLORI:** i colori delle pietre e dei mattoni riportati in questo catalogo possono avere tonalità leggermente diverse da quelle originali per motivi di stampa.

**COLOURS:** the colours of stones and bricks shown in this catalogue list may differ slightly in tonality from the originals due to the printing process.

**FARBEN:** Aus drucktechnischen Gründen können die Farben der abgebildeten Steine und Ziegel im Katalog leicht von den Originalfarben abweichen.

**COULEURS:** les couleurs des pierres et des briquettes dans ce catalogue peuvent avoir une tonalité légèrement différente de celles originales pour raison d'imprimerie.

# Pietred'Arredo<sup>®</sup>

naturalmente ricostruite

[www.pietredarredo.it](http://www.pietredarredo.it) | [info@pietredarredo.it](mailto:info@pietredarredo.it)



## UFFICI COMMERCIALI, DEPOSITI E SHOW ROOM

### Gubbio (PG)

Z. I. Padule, Via Topino, n. 11 - 06024 - Gubbio - ITALY  
tel. +39 075 923561 - fax +39 075 9221174

### Sassuolo (MO)

Via Regina Pacis, n. 226 - 41049 - Sassuolo - ITALY  
tel. +39 0536 855161 - fax +39 0536 851878

**bimobject**<sup>®</sup>

**SYNCRONIA**  
ARCHITECTURE VICTIMS

*powered by*

**COLMEF**  
— group —

Colmef srl - Z. I. Ponte d'Assi - 06024 Gubbio (PG) - ITALY - tel. +39 075 923561 - [info@colmef.com](mailto:info@colmef.com) - [www.colmef.com](http://www.colmef.com)



# Pietred'Arredo<sup>®</sup>

naturalmente ricostruite